

181 Bottles Inverter Dual Zone Touch Control Wine Cellar

181 支變頻雙溫區觸控式酒櫃



Inverter Compressor for accurate temperature control with quiet operation

變頻壓縮機令溫度控制更精準及運行更寧靜

Individual Dual temperature zone with Touch key control panel

獨立雙溫區設計及觸控電子控制面板

Low – Emissivity glass door for anti-UV and condensation

低輻射鍍膜防紫外線及防凝霧玻璃門

Deodorizing Air Circulation System with Active Carbon Filter

備有去異味活性炭濾網的空氣循環系統

Vertical storage basket for various bottle types

備有放置籃以直立放置不同類型酒瓶

Show case shelves present your collection

顯示層架方便展示酒藏

Blue LED Lighting

內置藍色LED燈

Sliding shelves with beech wood structure

滑軌櫟木層架

Security lock system with keys

安全鎖連開關鑰匙

Environmentally-friendly refrigerant (R600a)

環保雪種 (R600a)

Model (Left Hinge)	型號 (左門較)	VZ181VDUG-L
Model (Right Hinge)	型號 (右門較)	VZ181VDUG-R
No. of Bottles Stored	盛載數量 (瓶)	Upper Racks 上層容量 : 89 Bottles 瓶 Lower Racks 下層容量 : 92 Bottles 瓶
Capacity (Liters)	容量 (公升)	482
Shelving Material	層架物料	Beech wood 櫟木
Temperature range	溫度範圍	上及下儲酒區 Upper & Lower zone : 5°C - 20°C
Climate Classification	操作環境溫度	10°C - 32°C
Power & Voltage	功率及電壓	280W / 220-240V~ / 50 Hz
Product Dimensions (H x W x D) mm	產品尺寸 (高x闊x深) 毫米	1835 x 655 x 685
Product Net Weight (kg)	產品淨重 (公斤)	128

Specifications may change due to product improvement, No prior notice will be given.

規格如有修改，恕不另行通知。

Installation Diagram
推入式安裝圖

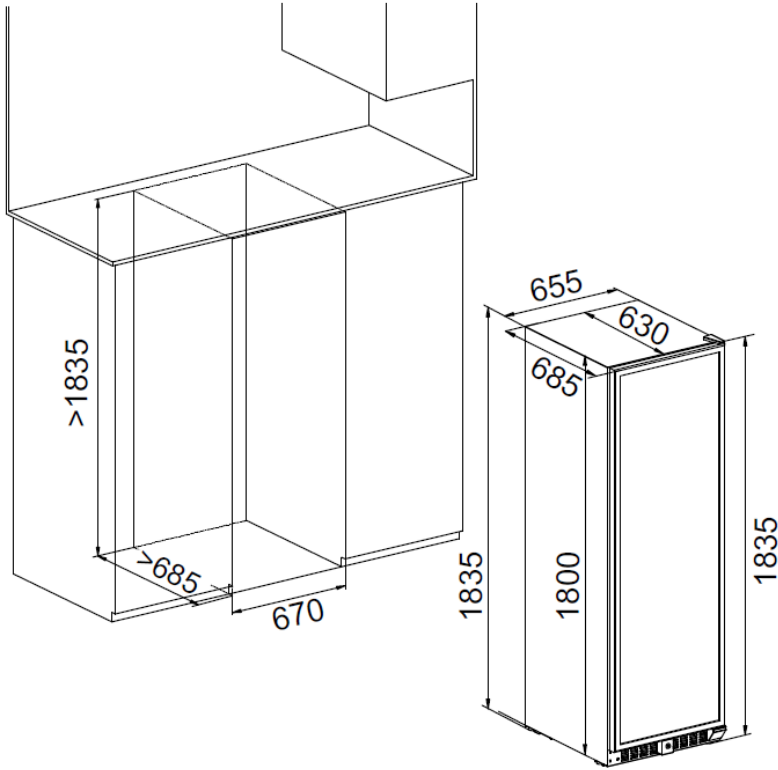

Loading Diagram
酒瓶裝載圖

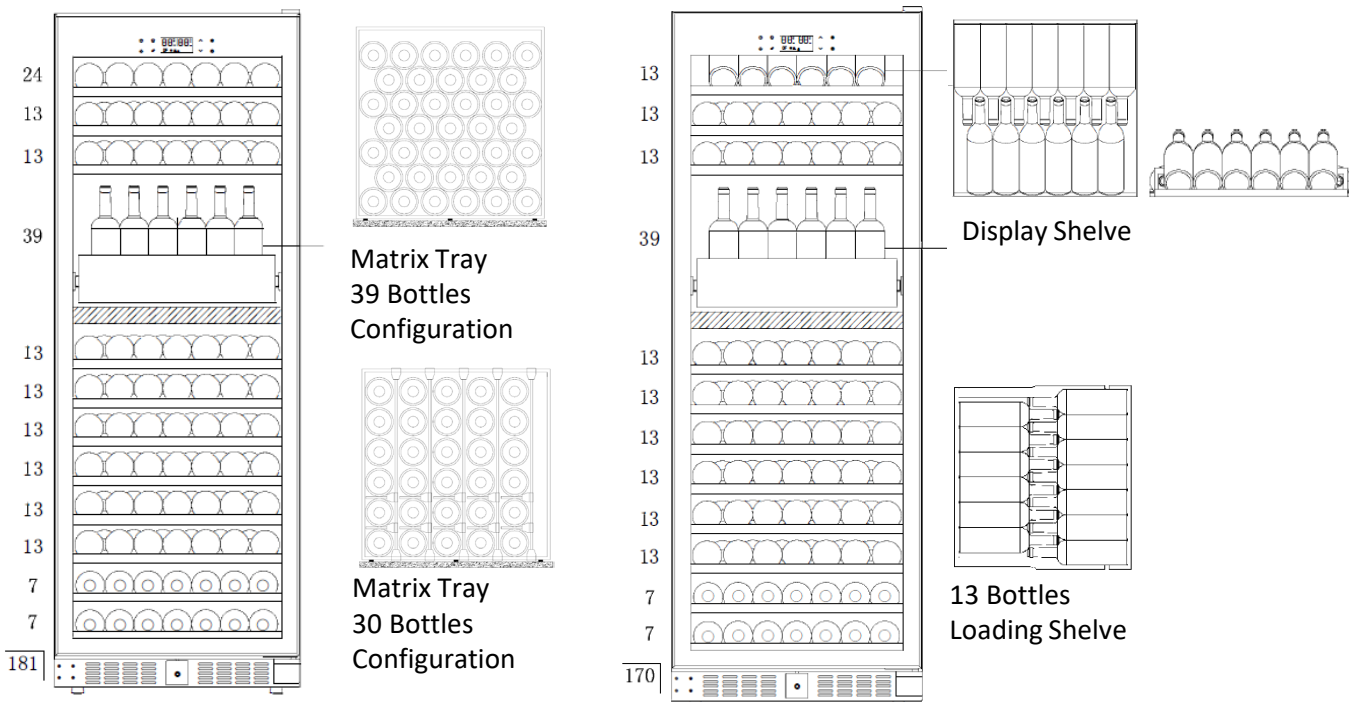

Specifications may change due to product improvement, No prior notice will be given.

規格如有修改，恕不另行通知。