

PHILCO® 

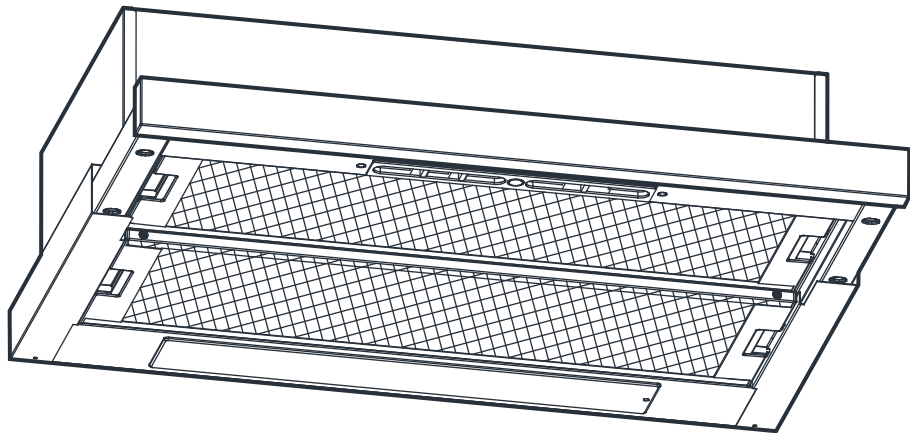

USER MANUAL

用戶手冊

GH609VNL



Dear Customer

Thank you for buying our range hood. Please read the user manual carefully and store in a handy place for later reference.

This hood is designed for fitting in a cabinet.

Read the following carefully to avoid damage or injury.



SAFETY AND WARNINGS

- Where applicable, this appliance is supplied with fixings. Please ensure you use the correct fixings suitable for the substrate where the appliance will be installed and that they are able to support the weight of the appliance.
- Before connecting the hood, check that the supplied voltage and frequency match with that indicated on the appliance rating plate. If in doubt, ask for advice instore or from a qualified installer.
- If the supply cord is damaged, it must be replaced by the manufacturer, its service agent or similarly qualified persons in order to avoid a safety hazard.
- Use only the same size of fittings and mounting screws as recommended in this instruction manual. Failure to follow these instructions may result in electrical hazards.
- Means for full disconnection must be incorporated in the fixed wiring in accordance with the local wiring installation rules for your country. An all-pole disconnection switch having a contact separation of at least 3mm in all poles should be connected during installation.
- When the extractor hood is located above an appliance, the minimum distance between the supporting surface for the cooking vessels on the hob and the lowest part of the hood shall be at least 650mm.
- Consult local regulations regarding extraction outlets and ensure these are complied with. Do not connect the hood to a ventilation

or hot air duct containing combustion fumes from burning gas or other fuels. Confirm that room ventilation is appropriate with the local authorities.

- The air must not be discharged into a flue that is used for exhausting fumes from appliances burning gas or other fuels
- The hood may stop working during an electrostatic discharge (e.g. lightning). This involves no risk of damage. Switch off the electricity supply to the hood and reconnect after one minute.
- This appliance can be used by children aged from 8 years and above and persons with reduced physical, sensory or mental capabilities or lack of experience and knowledge if they have been given supervision or instruction concerning use of the appliance in a safe way and understand the hazards involved. Children shall not play with the appliance. Cleaning and user maintenance shall not be made by children without supervision.
- This appliance is not intended for use by persons (including children) with reduced physical, sensory or mental capabilities, or lack of experience and knowledge, unless they have been given supervision or instruction concerning use of the appliance by a person responsible for their safety.
- Children should be supervised to ensure that they do not play with the appliance.
- Do not install the appliance outdoors in a damp place or in an area which may be prone to water leaks such as under or near a sink unit. In the event of a water leak affecting the appliance, do not use and contact customer services to arrange for inspection.
- Do not use flammable sprays in close vicinity to the appliance.
- Please dispose of the packing material carefully. There is a fire risk if cleaning is not carried out in accordance with the instructions. Refer to the Care and Maintenance sections carefully for details on how to clean and replace the aluminium and carbon filters (if fitted).
- Refer to the Care and Maintenance section for details on the type of lamps that can be used and how to replace them.
- Do not use a steam cleaner for care and maintenance.
- The appliance is not intended to be operated by means of an

external timer or separate remote control system.

- There shall be adequate ventilation of the room when the hood is used at the same time as appliances burning gas or other fuels. Ensure that the negative pressure of the installation site does not exceed 4 Pa (0.04 mbar) to ensure combustion fumes are not drawn back into the room.
- Do not use the hood if it shows signs of damage or imperfection. Contact customer services for assistance.
- Switch off the appliance at the mains supply before carrying out any maintenance work or cleaning.
- **CAUTION:** Accessible parts may become hot when used with cooking appliances.
- Do not flambé under the hood. To avoid the risk of fire, clean or replace the grease filter regularly and closely monitor pans containing hot oil.
- The manufacturer declines all liability for personal or material damage as a result of misuse or incorrect installation of this appliance.
- The appliance is for domestic use only as an extractor hood.

INSTALLATION INSTRUCTIONS

All installation must be carried out by a competent person or qualified electrician. Before connecting the mains supply ensure that the mains voltage corresponds to the voltage on the rating plate.

The appliance must be connected directly to the mains using an omnipolar circuit breaker with a minimum opening of 3mm between the contacts.

The installer must ensure that the correct electrical connection has been made and that it complies with the wiring diagram.

Regularly check the power plug and power cord for damage. If the supply cord is damaged, it must be replaced by a special cord or assembly available from the manufacturer or its service agent.



WARNING: This is a Class II appliance and MUST NOT be earthed.

Contents of packaging

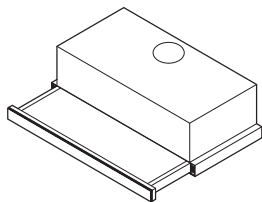

Rangehood
(1)

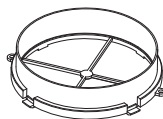

Ø120mm
Ducting adapter
(1)

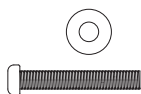

Screw M6 x 40mm
(including washer)
(4)



Screw ST3 x 12mm
(2)

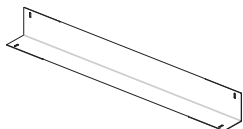

Rear Spacer
(1)

INSTALLATION

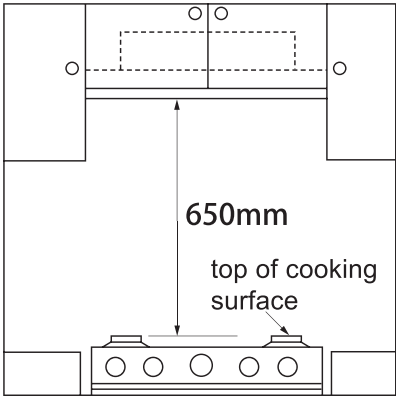

Positioning

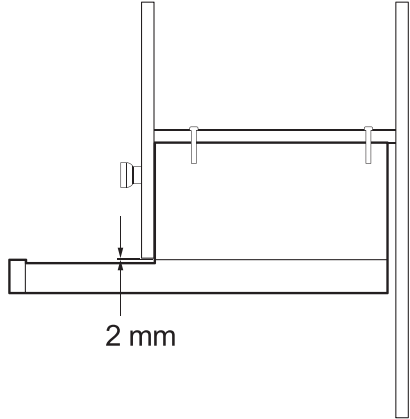

Fixing dimensions

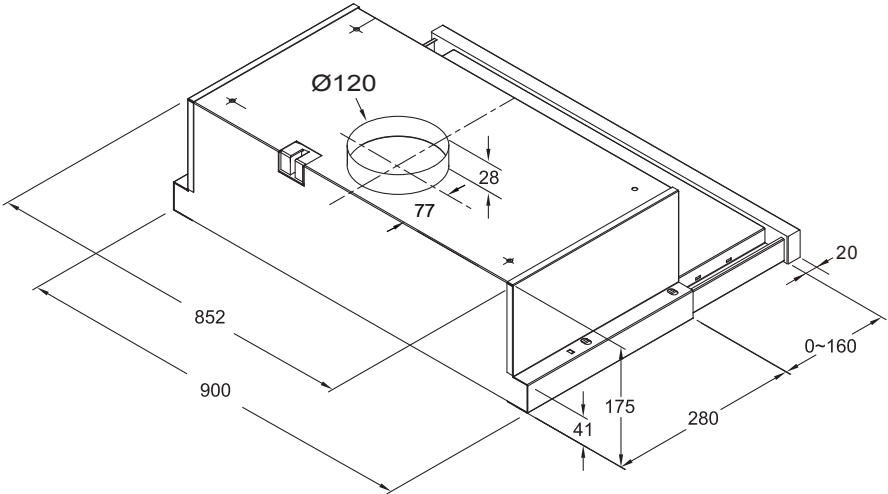

WARNING!

Failure to install the screws or fixing device in accordance with these instructions may result in electrical hazards.

Drilling holes

Drill the holes on top of wooden cupboard

- drill \varnothing 7mm hole
- cut \varnothing 140mm hole

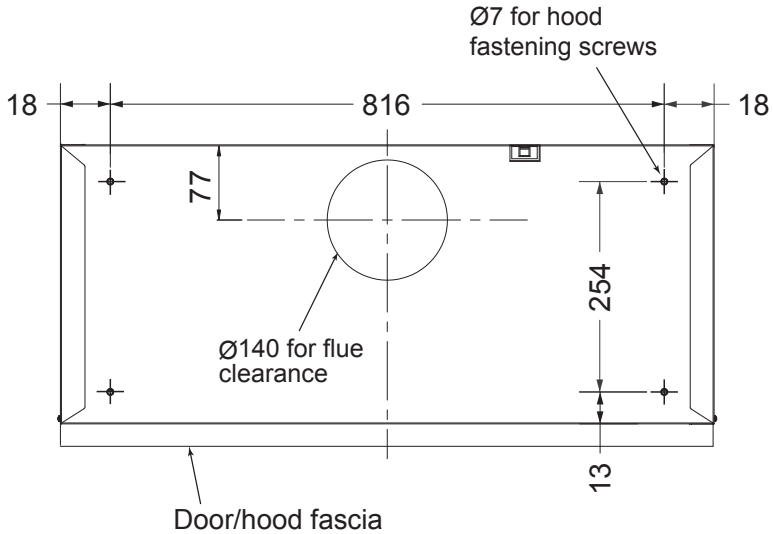

Fixing the ducting adapter

Connect \varnothing 120mm ducting adapter to the blower outlet.

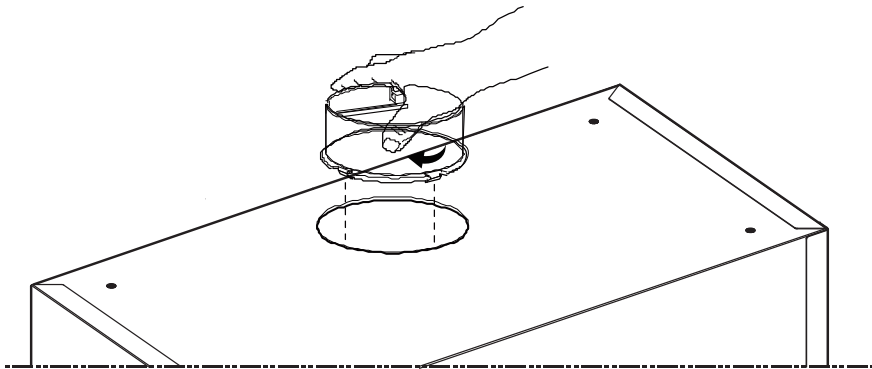

Mounting the rangehood to the underside of cupboard

Attach the rangehood to wooden support and fix it with the 4 screws supplied.

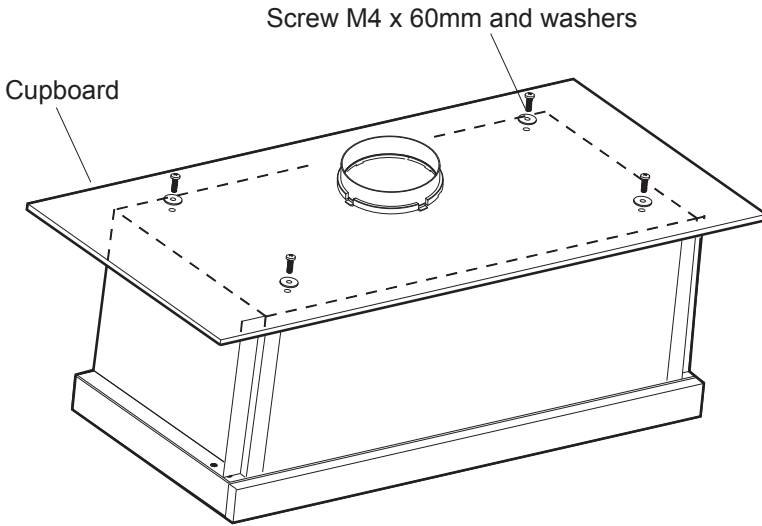

Fixing the Rear Spacer

Use suitable Rear Spacer to cover the space between the wall and the rangehood and fix it with 2 screws.

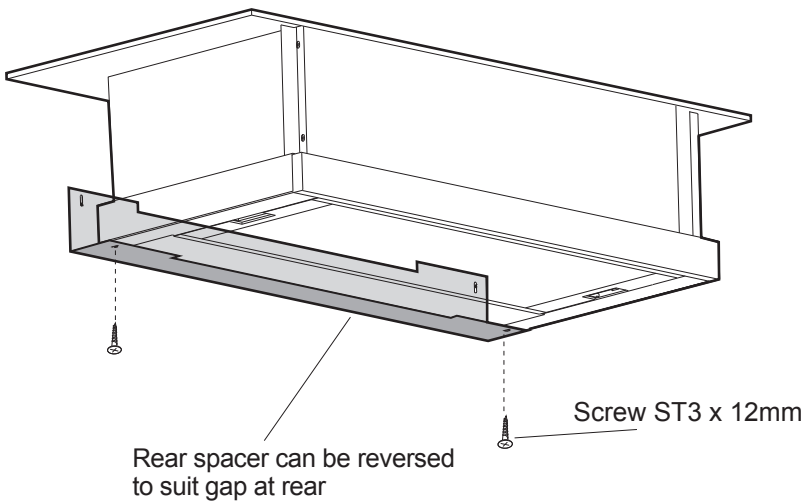

Fixing flexible duct

Connect Ø125 mm flexible duct to the adapter and fix it.

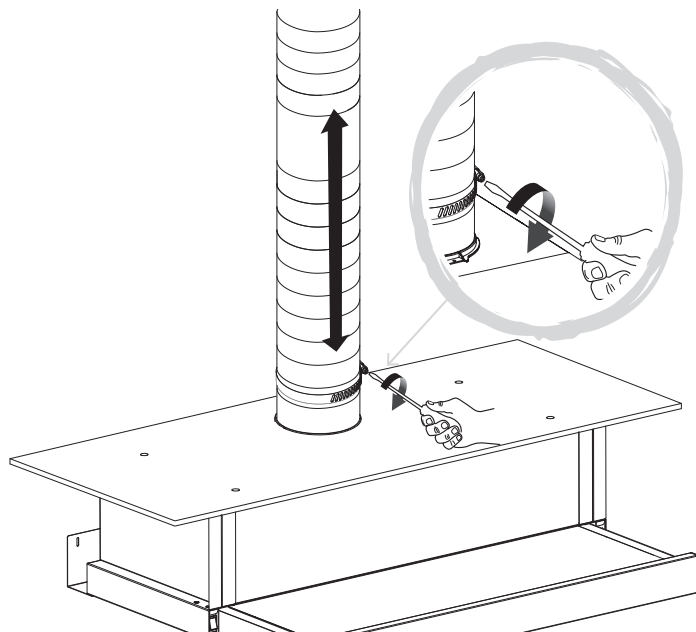

OPERATING INSTRUCTIONS

Control panel features

To operate the rangehood, pull out the retractable hood and select the extraction level.

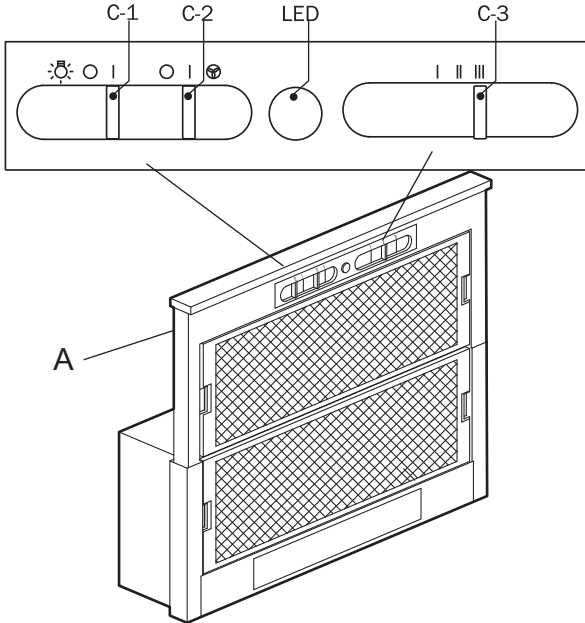

- Pull out the grill (A) as far as possible to 160 mm to achieve the ideal smoke efficiency.
- Slide the switch (C-1) from position “O” to “I” to turn on the light.
- Slide the switch (C-2) from position “O” to “I” to turn on the extractor fan.
- Slide the switch (C-3) to different position “I” , “II” and “III” to select low, medium or high speed.



Warning: the lighting should not be used as permanent light source but only for cooking.

CLEANING AND MAINTENANCE



Warning: always switch off the electricity supply before carrying out maintenance work on the hood. In the event of a fault, contact an official distributor or Customer Service.

Exterior Cleaning : Use non-corrosive, liquid detergent and avoid the use of abrasive cleaning products.

Replacing the lamp

Ensure that the rangehood is unplugged, then slide out the retractable hood and remove the filters. Turn the lamp anti-clockwise to remove then replace the lamp by turning it clockwise.

Note that lamps become hot when in use. Allow the lamps to cool down for a few minutes before changing them.

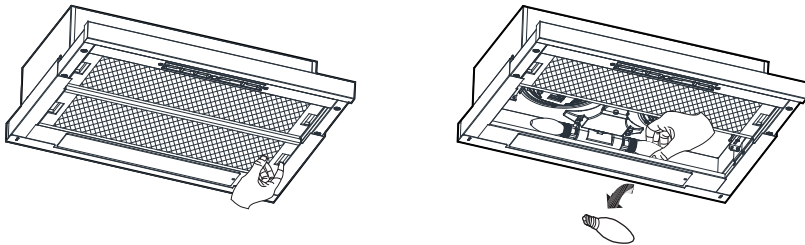
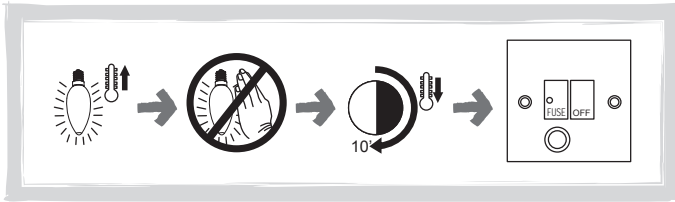

Cleaning Aluminium grease filters

Important! increase the filter cleaning/replacement frequency if the hood is used for more than 2 hours a day. Always use genuine filters from the manufacturer.



1 MONTH

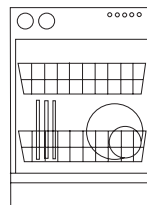
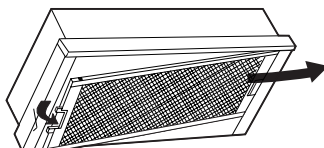
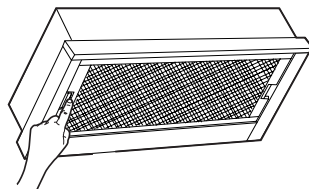

≤ 65°C

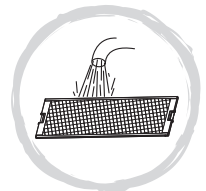

Replacing Activated charcoal filters

Replace Activated charcoal every 3 months



3 MONTHS

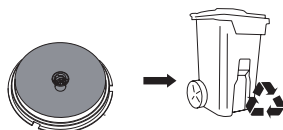
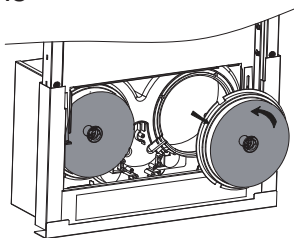
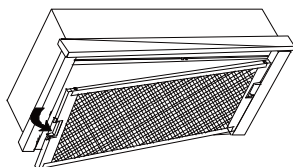

Troubleshooting

Problem	Possible cause	Solution
Excessive vibration.	The appliance is not installed properly on the brackets.	Take down the appliance and check it is properly fixed.
	The fan blade is damaged.	Switch off the appliance. Repair to be carried out by qualified service personnel only.
	The fan motor is not fixed tightly.	
The light is on, but the fan does not work.	The fan blade is jammed.	Switch off the appliance. Repair to be carried out by qualified service personnel only.
	The motor is damaged.	
Both the light and motor do not work.	Light bulb blown.	Replace with a bulb of the correct rating.
	Power connection loose.	Check power supply.
Suction performance reduced.	Speed may be too low.	Select a higher speed.
	Aluminium filters are dirty.	Clean the aluminium filters. (See Care and maintenance section).
	Top vent might be obstructed.	Clear any obstruction.
	Optional vent kit might be twisted.	Ensure that the vent kit is fitted according to the manufacturer's instructions.
	The installation may not comply with the manufacturers instructions.	The vent hose should be correct diameter throughout with no reductions or restriction.(See installation section).
Works normally but cooking smells linger.	Carbon filter is not fitted in recirculation mode or is full of grease.	Fit carbon filter or replace the carbon filter (See Care and maintenance section).

Recycling & disposal



The symbol on the product or on its packaging indicates that this product may not be treated as household waste. Instead it shall be handed over to the applicable collection point for the recycling of electrical and electronic equipment.

By ensuring this product is disposed of correctly, you will help prevent potential negative consequences for the environment and human health, which could otherwise be caused by inappropriate waste handling of this product.

For more detailed information about recycling of this product, please contact your local city office, your household waste disposal service or the shop where you purchased the product.

中文

親愛的顧客

感謝閣下購買了飛歌牌抽油煙機。請仔細閱讀本用戶手冊並妥為保存，以供日後參閱。

此抽油煙機只適合安裝於廚櫃中。

請小心閱讀下列事項以避免損壞或受傷。



安全及注意事項

- 本機附有原裝材料以供安裝使用。在任何情況下，必須依照安裝指示，使用正確的配件安裝，並確保安裝的牆壁或支架有足夠的承托力。
- 使用前先校對抽油煙機銘牌的額定電壓與功率相符，選用與插頭相適配的插座(如適用)。如果有任何疑問，請與合資格的技術人員查詢。
- 如果電源線損壞，必須由生產商，其服務代理或專業人士替換，以避免危險。
- 安裝時，必須使用與說明書上建議的螺絲及其他固定配件尺碼相同。如果不按照指示安裝，有機會引致觸電危險。
- 必須依據本地佈線安裝規則，將完全斷開的方法納入固定佈線。在安裝過程中，應連接全極斷路開關，而所有極之間的接觸距離至少為3毫米。
- 假如本抽油煙機是安裝在煮食爐具上方，請注意抽油煙機的底部與爐具之間的最少距離必須為650 毫米。
- 請參考閣下當地有關於油煙排放標準的規定。請勿將抽油煙機與其他排煙管道、通風管道或熱風管道連接。請向當地權威機構確認室內通風條件是否適合安裝。
- 請勿將排出的油煙接合到氣體或任何煮食爐的排氣管道中。
- 抽油煙機可能會在靜電放電時停止運作(如閃電時)。這不會造成抽油煙機的損壞。此時，請把電源關掉，等一分鐘後再重新開啟。

- 在有人從旁指導，保證其安全使用抽油煙機及明白相關危險的情況下，8歲或以上的兒童、障礙人士(包括生理、感官、心理)或缺乏知識經驗者均可使用本抽油煙機。應注意切勿讓兒童玩弄本抽油煙機。在沒有人監督下切勿讓兒童進行清潔或日常保養本抽油煙機。
- 請勿讓不合適的人士，如障礙人士(包括生理、感官、心理)，兒童或缺乏知識經驗者使用。除非有人從旁指導，保證其安全使用抽油煙機。
- 應注意照顧兒童，防止兒童玩弄本抽油煙機。
- 請勿將本抽油煙機安裝在戶外潮濕的地方或任何接近有洩漏水源的地方，例如安裝在水槽下方或是附近。如果抽油煙機受到漏水所影響，立即停止使用。並即時聯絡客戶服務部安排合資格技術人員檢驗。
- 切勿在抽油煙機附近噴灑易燃的物體。
- 請小心棄掉所有包裝物料，勿讓兒童把玩，免生意外。請依照使用手冊定期清潔抽油煙機，以免發生火災危險。請仔細參閱“日常清潔及保養”章節關於如何清潔及替換金屬隔油網和炭濾網(如有安裝)。
- 請參閱“日常清潔及保養”章節關於照明燈的種類及更換方法。
- 切勿使用蒸氣工具清潔本抽油煙機。
- 本抽油煙機並非配合外置計時器或外置遙控器使用。
- 請確保當抽油煙機與其他燃氣設備同時在運作時，室內必須有足夠空氣流通。確保室內家用電器的最大排氣負壓率不超過 4 Pa (0.04 mbar)，以防止燃燒氣體被回抽到室內。
- 若發現抽油煙機出現損壞或瑕疵，請勿使用。應聯絡客戶服務部，讓合資格技術人員檢查。
- 在清潔及保養抽油煙機前，請先關上供電電源。
- **注意事項:** 在使用燃氣爐具時，抽油煙機附近的零部件可能會受熱。
- 為避免火災危險，請勿在抽油煙機下方直接燒烤食物。應定期清洗或更換金屬過濾網。如鍋內正在烹煮熱油，必須緊密關注。
- 任何因為不適當或不正確使用本抽油煙機而導致的個人或物料的影響，生產商將不會承擔責任的。
- 本抽油煙機是只作一般家庭使用。

安裝指南

本抽油煙機之全部安裝工序必須由合資格及有能力技術人士進行。在連接電源之前，請先校對並確認抽油煙機銘牌的額定電壓應與使用電壓相符。本抽油煙機必須連接到附有斷路器的主插座上，當中必須保持有**3毫米**間距。

安裝技術人員必須確保有正確的電源接駁並符合接線圖。定期檢查電源線及插頭是否有破損。如果發現電源線有損壞，必須聯絡客戶服務部，由獲授權的合資格技術人員更換由生產商提供的特定電源線。



注意事項: 本抽油煙機是第II類電器，並切勿安裝接地線。

抽油煙機及內附配件

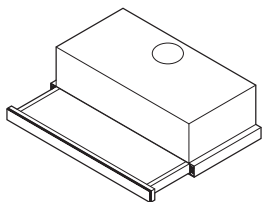

抽油煙機
(1)

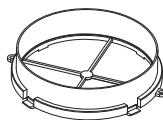

Ø120毫米
排氣管接合器
(1)

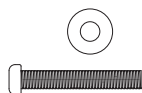

螺絲 M6 x 40毫米
(包括介子)
(4)



螺絲 ST3 x 12毫米
(2)

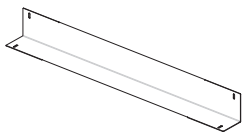

後方收口墊片
(1)

安裝

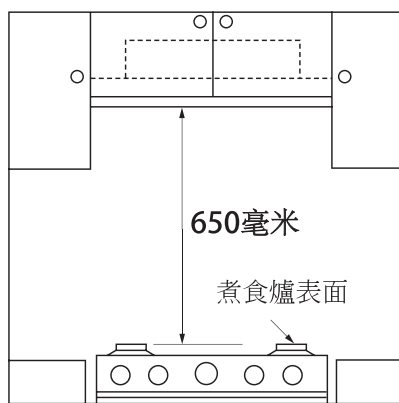

位置

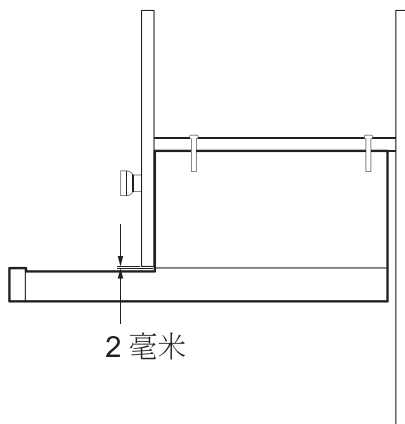

安裝尺寸

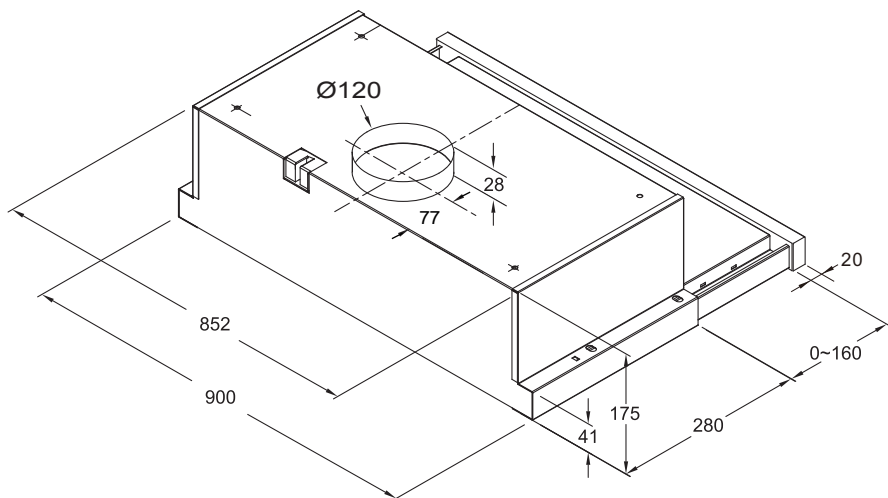

注意事項!

如果未有依照以上指示安裝螺絲及固定裝置會引致觸電危險。

鑽孔

在廚櫃上方木板鑽孔

- 鑽孔 \varnothing 7毫米
- 開孔 \varnothing 140毫米

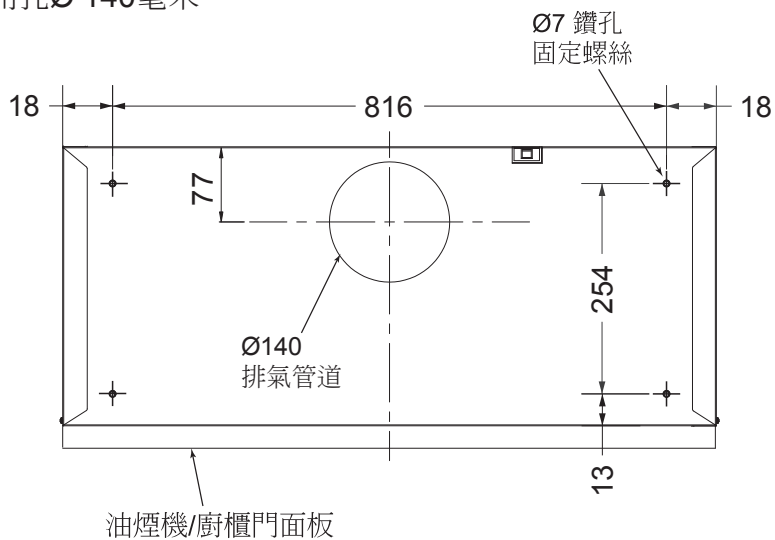

安裝排氣管接合器

將 \varnothing 120毫米排氣管接合器連接在排風口上。

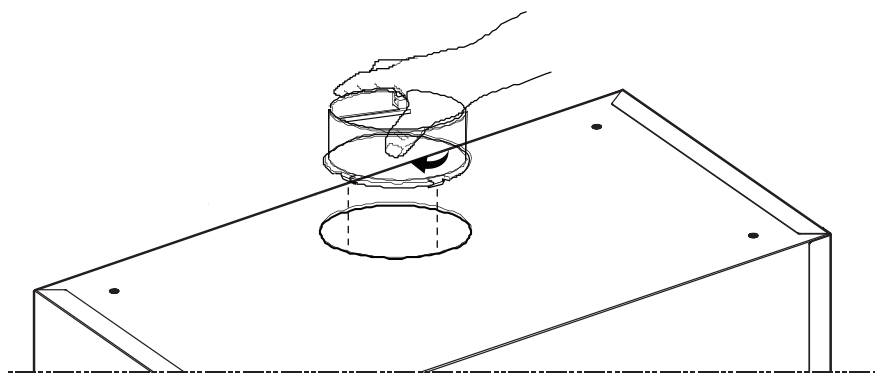

抽油煙機安裝到廚櫃的下面

將抽油機附著到木板上支撐，並與所提供的4個螺絲固定。

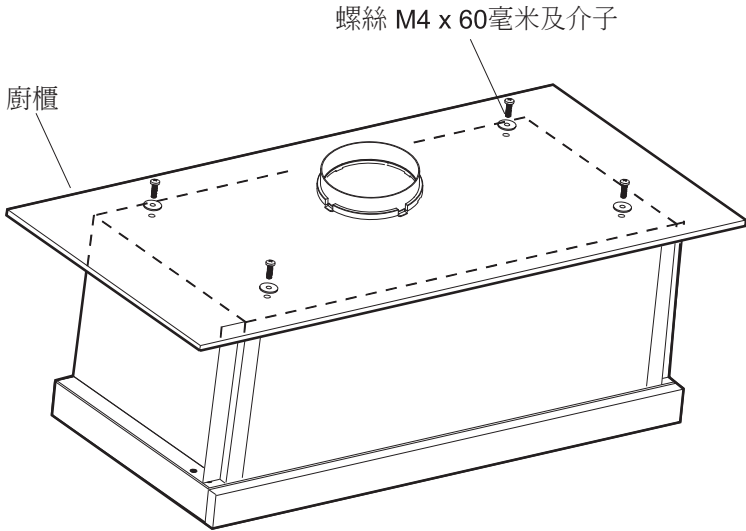

安裝後方墊片

選擇尺寸合適的墊片以掩蓋抽油煙機與牆壁之間的隙縫。使用隨機附設的2粒螺絲固定。

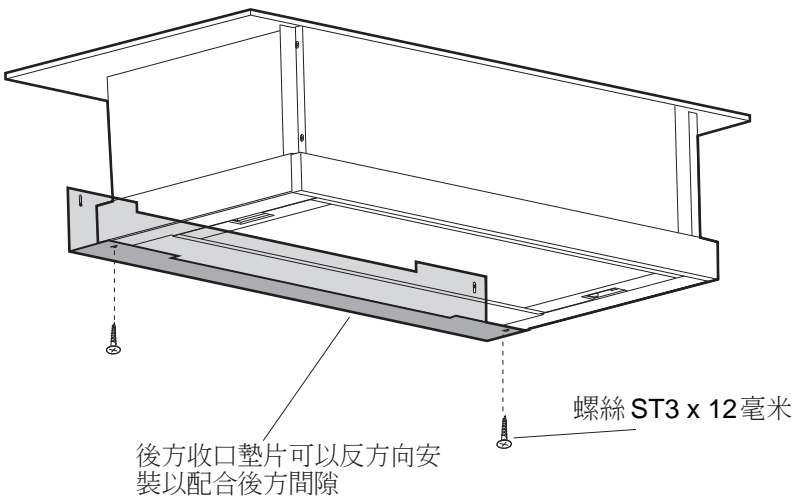

安裝伸縮排風管

將Ø125毫米的伸縮排氣管連接在接合器上，並用螺絲固定位置。

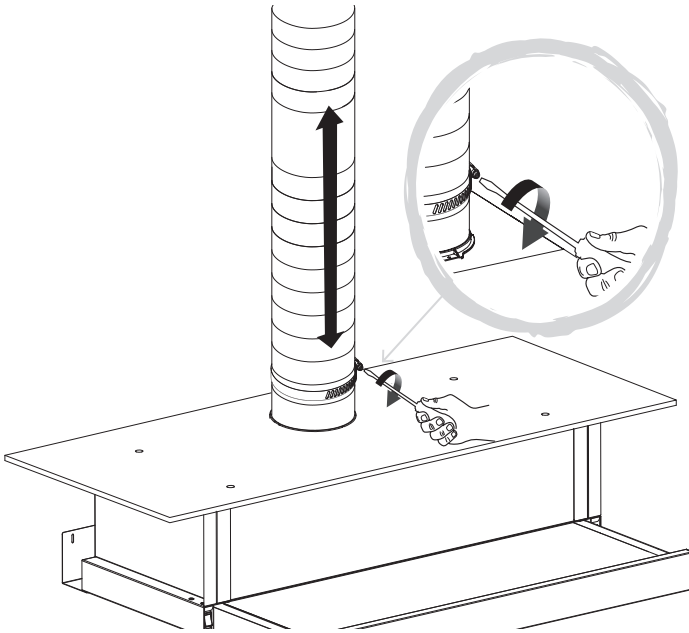

使用抽油煙機

控制面板

先將抽油煙機全面抽出，按動風速選擇掣以設定所須之風速。

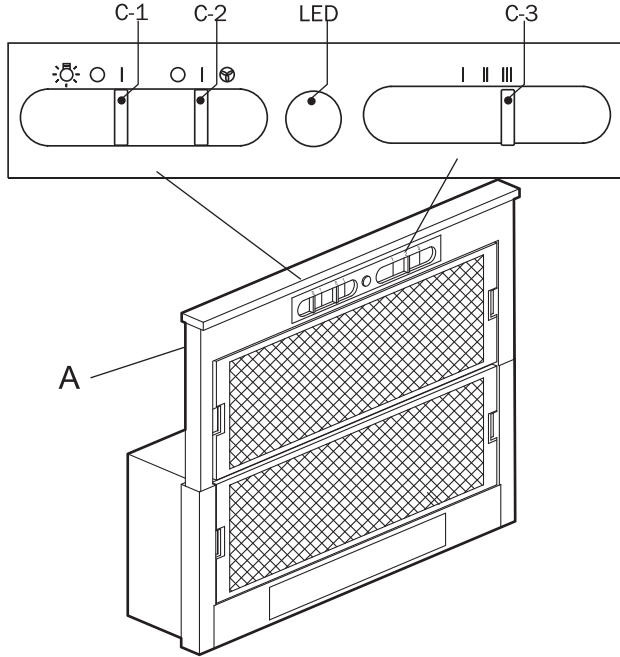

- 拉出抽油煙機前格柵 (A) 至160毫米，以達到理想的排煙效率。
- 將 C-1推掣由“O”位推至“I”位以開啓燈炮。
- 將 C-2推掣由“O”位推至“I”位以打開抽氣扇。
- 將 C-3推掣推至“I”，“II”及“III”選擇低速，中速及高速。



注意事項： 照明不應用作永久光源，而只能用於烹飪。

日常清潔及保養



注意事項： 在進行清潔及保養抽油煙機前，請先關閉供電電源。如發生故障，請聯絡客戶服務部。

清潔抽油煙機表面: 請使用不含腐蝕性的液體清潔劑，請勿使用含研磨劑的清潔產品。

更換照明燈

更換照明燈前，請先把電源關掉。將抽油煙機抽出並將濾網除下，將照明燈反時鐘方向轉動，移除並更換新的照明燈。向時鐘方向轉動後完成。

注意照明在使用中會變得非常熱。更換前等候數分鐘，讓燈冷卻。

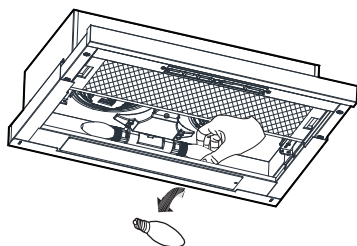
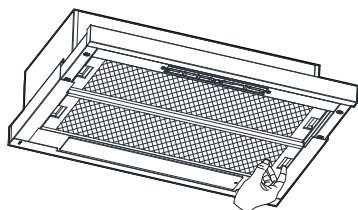
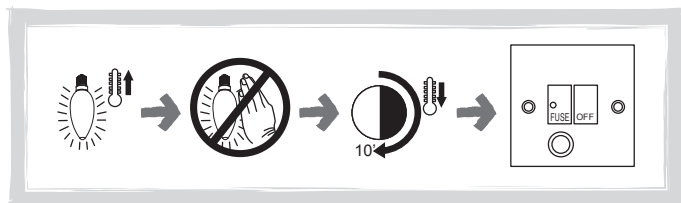

清潔抽油煙機金屬濾網

重要事項：如抽油煙機每天使用超過2小時，請增加過濾網的清洗次數。請務必使用由原廠生產的原裝過濾網。



1 個月

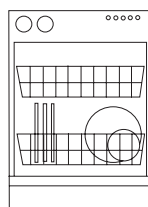
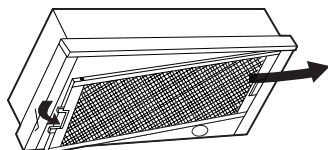
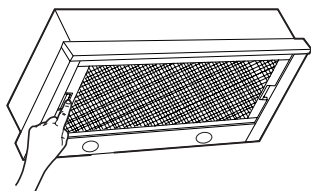

≤ 65°C

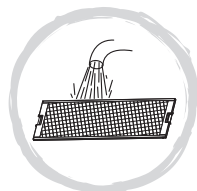

更換活性碳過濾網

請每三個月更換一次活性碳過濾網。



3 個月

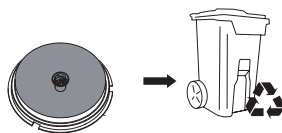
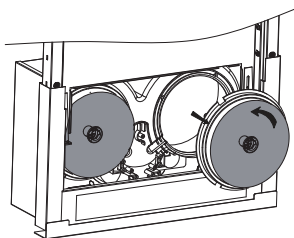
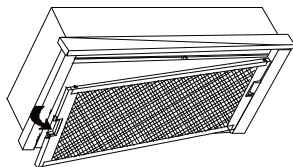

故障排除

問題	可能成因	解決方法
過度震動	油煙機托架未完全安裝妥善。	除下油煙機並重新檢查安裝是否完善。
	風扇扇葉損壞。	關掉油煙機致電維修服務中心，讓合資格的技術人員檢查及維修。
	風扇摩打未緊牢固定。	
操作顯示燈亮著，但風扇不運作	風扇扇葉被卡住。 摩打損壞。	關掉油煙機致電維修服務中心，讓合資格的技術人員檢查及維修。
操作顯示燈及風扇均不運作	照明燈泡損壞。 電源線及插座未完好地接上。	
抽吸力下降	風速選擇過低。	選擇高檔風速。
	金屬過濾網太污糟。	清潔抽油煙機金屬濾網。 (請參閱“日常清潔及保養”章節)
	頂部通風口可能受阻塞。	清理任何受阻塞物件。
	排氣喉可能被扭曲。	請確保排氣喉是依照生產商的指示而安裝。
	油煙機未有遵守生產商的指示安裝。	整條排氣管道必須使用同一正確直徑尺寸，不應縮減或阻塞。 (請參閱“安裝”章節)
油煙機操作正常但未能抽走煮食產生的混濁氣味	在室內循環過濾式操作模式下未有安裝活性碳過濾網，或是活性碳過濾網已充滿油漬。	安裝活性碳過濾網，或是更換活性碳過濾網。 (請參閱“日常清潔及保養”章節)

回收和處置



在本產品包裝或產品上標示著這符號，代表這產品不能以家居垃圾處理。相反應該把它交給適當的回收電器和電子用具的收集點處理回收。

在確保本產品被正確棄置的同時，閣下正協助防止因為不正當處理這些廢物而產生對環境和人體健康造成的負面影響。

要得到更詳細資料關於處理，回收和循環再用產品，請聯絡相關政府部門，家居廢物服務或零售商。

請記錄下列產品資料

● 型號

● 機身編號

● 經銷商名稱

● 購買日期

本產品不斷改進中，如功能有所更改，恕不另行通知，如有疑問，請與客戶服務中心聯絡，不便之處，敬請原諒。

說明書內容以英文版本為準

ToolBox Customer Service Centre 客戶服務中心：
4/F, DCH Building, 20 Kai Cheung Road, Kolwoon Bay, Hong Kong
香港九龍啟祥道20號大昌行集團大廈4樓

Customer Service Hotline 客戶服務熱線：(852) 8210 8210
Service E-mail 電郵地址：8210service@gilman-group.com
Please register now at 請即上網登記：www.toolbox.hk
Website 網址：www.gilman-group.com



a Gilman Group Company