



Brandt

**BUILT-IN
CATALOGUE**

Cooking

Brandt

本公司將不斷提升各型號之規格，以上產品資料與設計或有更改，恕不另行通知。
In order to improve our products, the above mentioned specifications and designs are subject to change without prior notice.



Brandt



Brandt understands that life can get complicated, so we've created products specifically designed to:

Make Life Simple



BV Cert. 6011825

Brandt has been granted the "**Origine France Garantie**" label by the Pro France association for all products made in its French manufacturing plants. This label, certified by **Bureau Veritas**, assures consumers that the product in question was made in France.



CONTENT

n	OVENS	03
n	MICROWAVE OVENS	09
n	STEAM OVENS	13
n	INDUCTION HOBS	15
n	HOODS	21

Brandt



DESIGN, FUNCTIONALITY AND PERFORMANCE

UNITED AS ONE

This collection is marked by Brandt's passion for design, research and rigorous attention to detail.

Sleek and refined, the seamless melding of glass to metal and the clean, sophisticated lines thrill aesthetic sensibilities.



INTUITIVE INTERFACE

Cooking modes and programme feedback are displayed against a Full Colored TFT screen or white backlight panels selected via sensitive touch controls. Electronic programming ensures precise temperature control in every function.



“ OVENS RANKED A+, MADE IN FRANCE

All Brandt pyrolytic ovens are rated A+, demonstrating excellent insulation and exceptionally controlled management of heating temperatures which contributes to significant energy saving. ”

TASTE THE DIFFERENCE

quattro PULSE

Brandt reinvents cooking with our extensively researched heat diffusion technology, Quattro Pulse and patented grill! Injection of heated air into the cavity is accelerated for uniform temperature within the cavity to ensure that cooking quality is perfectly consistent on all levels for excellent results.



OMEGA GRILL

Enjoy perfectly uniform cooking with the Brandt exclusive Omega Grill - precisely crafted to ensure your cooks and bakes turn out beautifully every time.



With Omega Grill



Without Omega Grill

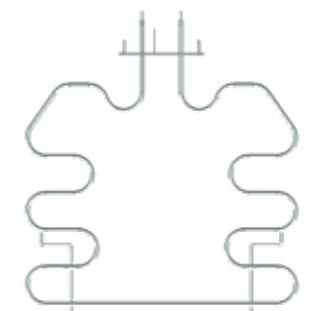

CLEAN & SAFE

COOL DOOR

With 4 layers of glass panes, it ensures your oven door surface is always kept cool throughout cooking and pyrolysis cleaning.

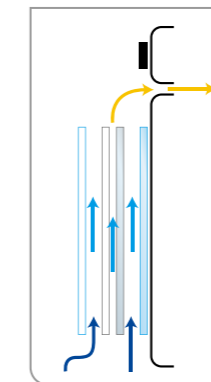

CLEAN 39'

Ultra fast and 50% more economical, this function uses residual heat from the previous cooking cycle to pyroclean the cavity in 39 minutes flat.

PYROLYSIS CLEANING EXPRESS P

This is the simplest, most efficient and economical type of cleaning. At high temperatures, oven self cleans greasy build up after successive uses and restores the cavity to look as good as new.

With 3 different Pyro cleaning cycles to choose from, Brandt pyrolytic ovens give you the flexibility for your everyday cleaning needs.

- Autocook
- Circulating Heat
- Fan Bottom
- Keep Warm
- Pyro
- Traditional
- Variable Grill
- Pyro Express*
- Traditional Fan
- Recipes
- Eco
- Grill Fan
- Clean 39'
- Steam Assisted**
- White Meat
- Fish
- Poultry



BOP7568LX

60cm Multifunction+ Oven 73L with 6 Shelf Levels + Telescopic
4 Cooking Modes - Expert, Recipes, Steam Recipes, Autocook
3 x Pyrolytic Cleaning Programs
Autocook Program
 Quattro Pulse Technology
 Electronic Touch with Full Color TFT LCD Display

Cooking Programs: 8(Expert), 9(Recipes), 10(Steam Assisted Recipes), 12(Autocook)
 3 Automatic Steam Assisted Programs: 4(Fish), 4(Poultry), 2(White Meat)
 Optional Functions: Smart Assist, Delay End, Demo Mode, Independent Timer
 Safeties: Child Lock, Auto Stop, Cool Door, Door Lock During Pyrolysis
 Product Dimensions (mm): H596 x W592 x D544
 Built In Dimensions (mm): H585 x W560 x ≥D545



BV Cert. 6011825

Installation Diagram BOP7568LX

In mm

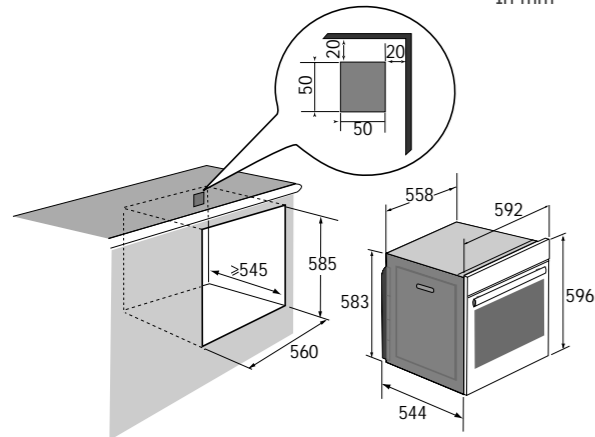

Autocook	Circulating Heat	Grill Fan	Keep Warm
Fan Bottom	Eco	Traditional	Pyro
Recipes	Variable Grill	Traditional Fan	Pyro Express
Pizza	Clean 39'		



BOP7537LX

60cm Multifunction+ Oven 73L with 6 Shelf Levels + Telescopic
Clean 39'
3 x Pyrolytic Cleaning Programs
Automatic Steam Assisted Programs
 Quattro Pulse Technology
 Electronic + Knob Control with LCD Display
 Cooking Programs: 6(Expert), 10(Steam Assisted)

3 Automatic Steam Assisted Programs: 4(Fish), 4(Poultry), 2(White Meat)
 Optional functions: Smart Assist, Delay End, Demo Mode, Independent Timer
 Safeties: Child lock, Auto Stop, Cool Door, Door Lock During Pyrolysis
 Product Dimensions (mm): H596 x W592 x D544
 Built In Dimensions (mm): H585 x W560 x ≥D545



BV Cert. 6011825

Also available in Black / BOP7537BB



Boost	Eco	Fan Bottom
Clean 39'	Variable Grill	Pyro
Circulating Heat	Grill Fan	Traditional

FOR YOUR CULINARY SUCCESS

REST EASY IN THE HANDS OF STEAM ASSISTED COOKING

Brandt offers you 3 new functions which automatically combine two cooking modes: traditional cooking and steam cooking in order to preserve the nutritional qualities of food and achieve faster cooking.



AUTOCOOK

Enjoy the best of French Culinary expertise with Brandt's patented AutoCook!

Choose your dish from one of the 12 proposed:

The oven automatically determines the temperature, ideal cooking mode and time for perfect cooking results, everytime.

Simply select your dish on the control panel, insert your ingredient(s) into the oven and let your oven do the rest!

Full Colored TFT Screen

Your cooking programme is displayed on a large colored TFT screen, which provides complete ease of use on the dish selected.

*Available for selected models only.



Installation Diagram BOP7537LX/BB

In mm

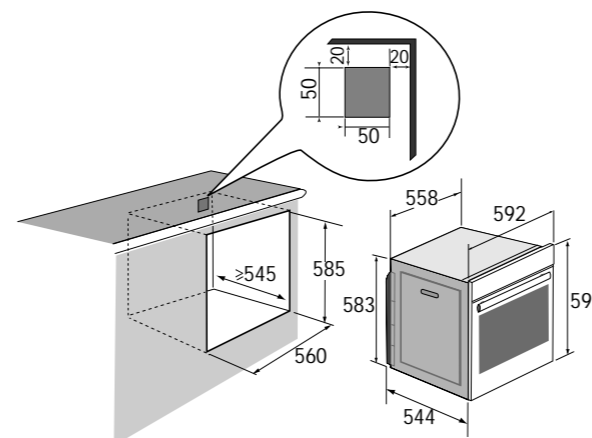

QUATTRO PULSE TECHNOLOGY COMBINED WITH ROTATING HEAT

TASTE THE DIFFERENCE

Diffusion of heated air into the cavity is accelerated for uniform temperature all around the cavity to ensure cooking quality is perfectly consistent on all levels for excellent results, every time.





BOC7532LX

**60cm Multifunction+ Oven
73L with 6 Shelf Levels
Catalytic Cleaning
Omega Grill
Automatic Steam Assisted Programs**

Quattro Pulse Technology
Electronic + Knob Control
with LCD Display
Cooking Programs: 5(Expert),
8(Steam Assisted)

2 Automatic Steam Assisted Programs: 4(Fish), 4(Poultry)
Optional Functions: Smart Assist, Delay End, Demo Mode, Independent Timer
Safeties: Child Lock, Auto Stop
Product Dimensions (mm):
H596 x W592 x D544
Built In Dimensions (mm):
H585 x W560 x ≥D545



BV Cert. 6011825



“ CATALYSIS

Brandt self-cleaning catalytic ovens feature specialised catalytic cleaning program, to automatically degrease your oven after every usage! Grease produced during each cooking cycle is evenly spread over the face of the catalytic enamel, immediately oxidising to disappear over time. Perfect for effortless maintenance of your oven!

ACCESSORIES

GREAT IDEAS ABOUND!

Brandt ovens are equipped with ingenious accessories designed to satisfy all your cooking desires.

THE MAXI DRIP TRAY: MAXIMUM SURFACE, MULTI-EFFICIENT!

With its sloped edge, it is ideal for cooking pastries (cream puffs, meringues, madeleines, puff pastry, etc.). When inserted into the supports under the grid, it collects juice and fat from grilling, and can also be used half filled with water as a double-boiler. Its XXL size provides you with an additional 40% of surface area.

THE ANTI-TIPPING SAFETY GRIDS: STABILITY = SAFETY!

Designed to hold all types of dishes or pans for cooking or browning, these grids can be pulled out up to three-quarters of their length and remain perfectly stable. They are also extremely practical for grilling as you can place meats directly on them.

TELESCOPIC RAILS - EASE OF USE

The new sliding rail system makes cooking & baking more practical and easier to handle as the trays can be effortlessly pulled for simpler handling.

Installation Diagram BOC7532LX

In mm

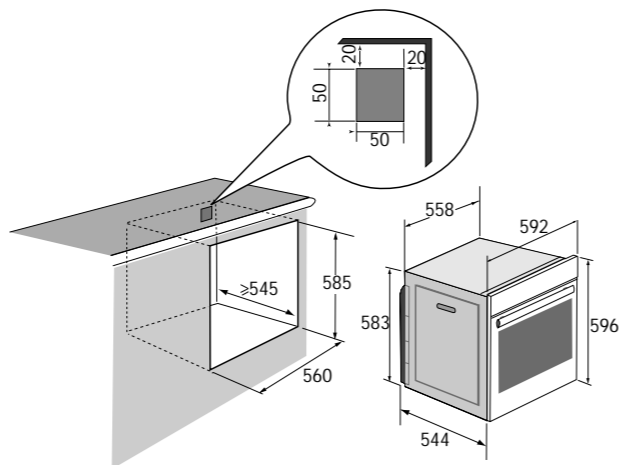

BOH7532LX

**60cm Multifunction+ Oven
73L with 6 Shelf Levels
Hydrolyse Cleaning
Omega Grill
Automatic Steam Assisted Programs**

Quattro Pulse Technology
Electronic + Knob Control
with LCD Display
Cooking Programs: 5(Expert),
8(Steam Assisted)

2 Automatic Steam Assisted Programs: 4(Fish), 4(Poultry)
Optional Functions: Smart Assist, Delay End, Demo Mode, Independent Timer
Safeties: Child Lock, Auto Stop
Product Dimensions (mm):
H596 x W592 x D544
Built In Dimensions (mm):
H585 x W560 x ≥D545



BV Cert. 6011825



Installation Diagram BOH7532LX

In mm

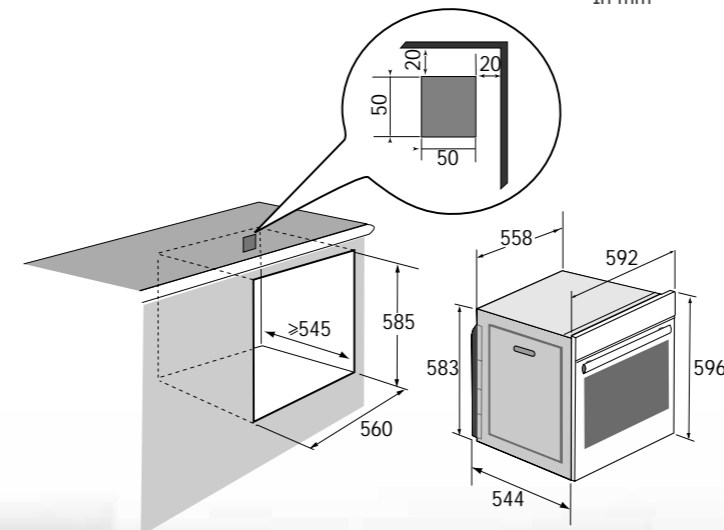

“ STEAM CLEANING OF THE CAVITY

Thanks to this function, you will spend less time cleaning your oven, with an Eco-Responsible action.





BEAUTY AND UTILITY IN ONE

COMFORT

With a clean backlit display, Brandt microwaves provide clear feedback and allow for precise tuning of programmes.

MEMO ACTIVE FUNCTION

If the same function has been used during the last three cooking sessions, it will be memorized and automatically suggested at the next cooking session.

DESIGN

The Brandt microwave collection has a perfect harmony of style and substance with a full glass front, a sleek handle and clean lines to level up your kitchen's style quotient.



EXEMPLARY COOKING QUALITY

CONVECTION

The rotating heat of the combi-microwave ensures you professional results every time. What's more, cooking time can even be reduced by up to 40%!

AUTO PROGRAMME: PERFECT RESULTS EVERY TIME!

The Auto Programme function allows you to cook with ease! Simply select the food type and indicate its weight: the appliance automatically recommends the appropriate cooking mode and time. The memory function also allows you to save the settings of up to 3 functions for easy cooking!



QUATTRO SYSTEM

The Quattro system ensures optimal diffusion of the waves inside the cavity with 4 waves and a distributor. Your dishes will be thawed, cooked or reheated evenly.

EASY INSTALLATION

For easy installation, Brandt built-in microwaves have standard cut-out sizes, making it easy for you to switch it up whenever you want. Other models are supplied with mounting kits.





BKC7153LX

45cm Combi Microwave Oven
40L with 3 Shelf Levels
10 Microwave Levels
3 Cooking Modes - Microwave, Combination, Traditional
Automatic Cooking Guide Program
 Quattro Pulse Technology
 Electronic Touch with LCD Display
 Keep Warm Function
 Cooking Programs: 10(Microwave), 3(Combination), 3(Traditional)



Automatic Cooking Guide:
 15 Dishes
 Optional Functions: Smart Assist, Active Memo', MEMO, Delay End
 Safeties: Keypad Lock, Turntable Stop, Auto Stop
 Product Dimensions (mm):
 H456 x W592 x D547
 Built In Dimensions (mm):
 H450 x W560 x ≥D550

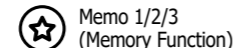
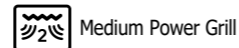
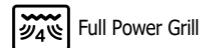
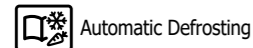
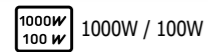

COOKING GUIDE: THE WINNING COMBINATION

WITH A BEVY OF POSITIONS, YOUR BRANDT MICROWAVE CAN MANAGE ALL TYPES OF COOKING

Equipped with cooking guide programmes that automatically calculate the duration and cooking mode of the dish you want to cook, simply select the type of food and its weight, and let your microwave oven do the rest!

15 PRE-PROGRAMMED DISHES:

You must choose a pre-programmed food from the following list:

- | | |
|--|--|
| P01: Ready-to-cook frozen food | P09: Beef |
| P02: Ready-to-cook chilled food (combined function) | P10: Pork |
| P03: Frozen pizza (combined function) | P11: Ready-to-cook chilled food (microwave) |
| P04: Frozen pizza (traditional cooking) | P12: Fish |
| P05: Fresh pizza | P13: Fresh fibrous vegetables |
| P06: Quiche | P14: Fresh vegetables |
| P07: Savoury tart | P15: Frozen vegetables |
| P08: Poultry | |



BMS7120X

38cm Solo Microwave
29L with 3 Shelf Levels
5 Microwave Levels
Automatic Cooking Guide Program
 Quattro Pulse Technology
 Electronic Touch with LCD Display
 Keep Warm Function
 Automatic Cooking Guide:
 2(Cooking), 4(Defrosting)



Optional Functions: Smart Assist, Quick Start
 Safeties: Keypad Lock, Turntable Stop, Auto Stop
 Product Dimensions (mm):
 H390 x W592 x D474
 Built In Dimensions (mm):
 H380 x W560 x ≥D550

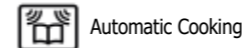
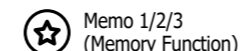

Also available in
 BLACK / BMS7120B



Installation Diagram BMS7120X/B

STAINLESS STEEL CAVITY

Brandt microwaves feature a stainless steel cavity to ensure complete food hygiene. The material's light reflecting properties also allow better visibility of your dishes whilst cooking!

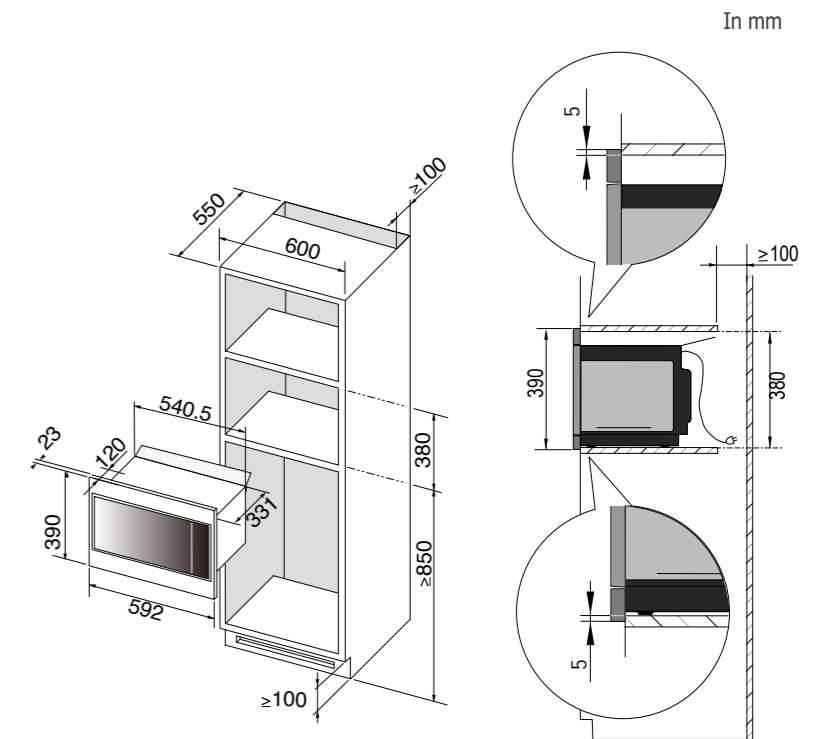

BRANDT THINKS FOR YOU QUATTRO SYSTEM

4 types of waves and a distributor provide optimal distribution of microwaves inside the cavity. The result: your dishes are defrosted, cooked or reheated evenly.

STEAM OVEN



STEAM OVEN



BKV7132LX

45cm Steam Oven
29L with 2 Shelf Levels
1L Removable Water Tank
Automatic Steam Programs
Sterilization Program
 Electronic + Knob Control
 with LCD Display
 Stainless Steel Cavity
 11 Cooking Programs
 10 Temperature Settings:
 55 - 100°C

Optional Functions: Smart Assist, Delay End, Demo Mode, Independent Timer
 Safeties: Child Lock, Auto Steam Evacuation, Auto Stop, No Water Indicator
 Product Dimensions (mm): H456 x W592 x D547
 Built In Dimensions (mm): H450 x W560 x ≥D550



Installation Diagram BKV7132LX



In mm

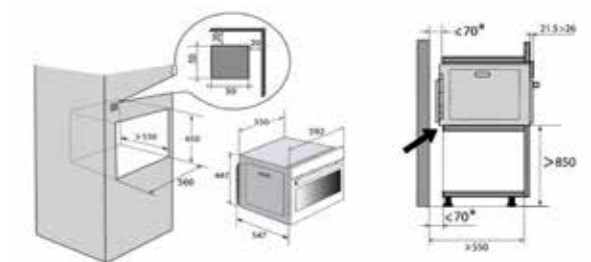

“ WATER TANK

It is so easy to install your Brandt Steam Oven! With the removable water tank, no water inlet is required! Just fill up the water tank before use. ”



STEAM OVEN

Besides steaming and defrosting, the Brandt Steam Oven is also a **multi-purpose appliance that makes healthier cooking easy.**

Gentle cooking without seasonings - The gentleness of steam cooking brings out natural flavours of your ingredients whilst preserving vitamins and minerals.

Reheating without compromising texture - Heating up food is quick and easy with the Brandt Steam Oven! Steam heats up your dishes without loss of moisture, rehydrating them for a flavourful meal.

Keeping warm - Your steam oven keeps your dishes warm for up to an hour after the end of the programmed timing for you to enjoy your dishes on your own time.

Defrosting without cooking - Keep your ingredients in perfect condition when you defrost with your Brandt Steam Oven. Precise and gentle steam temperature control ensures that your ingredients are defrosted without kicking off the cooking process.

Blanching ease - Preserve the texture and integrity of your ingredients when using the precise temperature control of your Brandt Steam Oven to blanch and prepare them.



COMPLETE EXPERTISE

INDUCTION THE BEST OF COOKING

Brandt remains at the forefront of induction technology, having led the shift to induction cooking in the late 1980s. Today, Induction Hobs account for more than 60% of cooking appliance sales!



A NEW ERA OF INDUCTION TECHNOLOGY

Sleek and trendy, Brandt Induction hobs have a perfect harmony of style and function with unrivalled performance and high heating capacities offered in each piece to meet all your cooking needs.

UNION OF FUNCTIONALITY AND COMFORT

PRECISE AND EFFICIENT COOKING

All induction hobs feature electronic controls for simplified usage. Touch sensitive keys and precise heating levels allow you to create perfect dishes, every time.

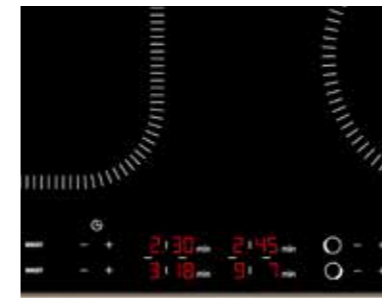

COOKING AIDES*

The Boost function brings you straight to maximum power. Brandt induction hobs allow you to programme your desired cooking duration and will automatically switch off induction hob at the end of the elapsed time. The Recall function allows you to pull up all the settings made (be it power level or timer) for your easy reference!

*Functions vary from models.



IMPECCABLE SAFETY

BRANDT'S 10 SAFETY MEASURES

All of Brandt's induction hobs are held to uncompromising safety standards to ensure the best cooking experience for you and your household.

10 SAFETY MEASURES:

Residual Heat Indicator to alert you when zones are still hot (after intensive use).

Small Object Detection to ensure small objects less than 10cm in diameter such as cutlery and cooking utensils are not heated.

Anti Overflow feature that switches the hob off when overflow spills onto control panel or when damp towel is placed over the buttons.

Auto-stop System which will automatically shut off the hob after if left on for overly long periods (depending on power level).

Key Lock Control that can be switched on when the hob is shut off or during cooking.

Automatic Saucepan Detection that ensures the cooking zone only operates when in contact with induction compatible cookware.

Temperature Limiter: This patented Brandt exclusive limits the temperature of the cooking zone to 300°C to prevent the risk of oil ignition.

Low Voltage, Connection Error and Over Tension Detection

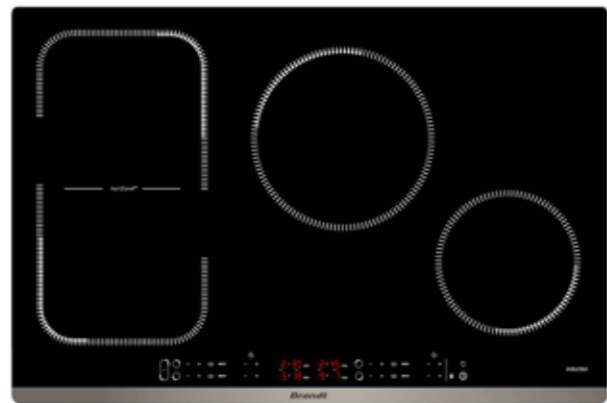

BPI6449BL

- 80cm Width
- 4 Zones
- Electronic Touch Sensitive Controls
- Booster and Recall Function
- Direct Access
- HoriZone Technology
- 10 Safety Features
- 9 Power Levels
- Vitroc ceramic Glass Top



400cm x 23cm - 4000W /
21cm - 3100W / 18cm - 2800W
99 Minutes Timer
Child Lock
Product Dimensions (mm):
H64 x W770 x D510
Built In Dimensions (mm):
W750 x D490

Installation Diagram BPI6449BL

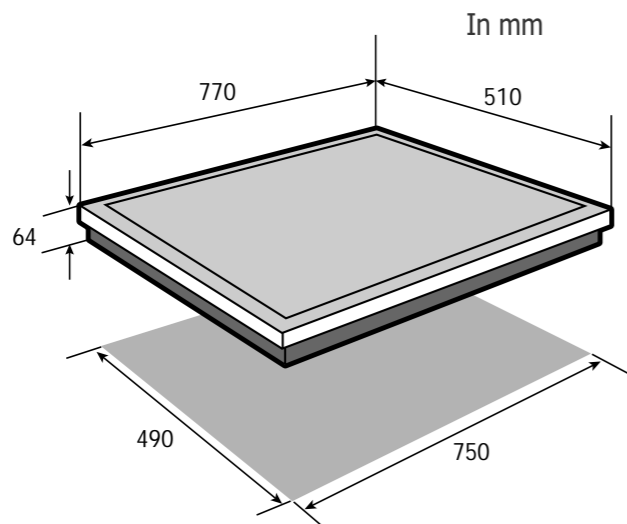

horiZone^{tech}

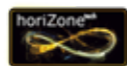

WELCOME TO THE INFINITE

Brandt showcases its expertise in induction cooking technology with the launch of horiZonetech technology. This zoneless cooking concept empowers you to push culinary creativity to the limits, heightening your cooking experience.

horiZonetech boasts a true zoneless induction cooking surface, being able to accommodate all shapes and sizes of cookware - from rectangular pans to oval dishes.



1 FREE, 2 CLASSIC

An ingenious combination of horiZone with a classic cooking surface allows you to express your culinary creativity to the fullest.

MULTIPLE CONFIGURATIONS FOR EVERY NEED

Flexible and precise with its adjustable direct access and numerous power levels, horiZone also boasts high heating capacity, with power reaching up to 4000W.



1 large zone for:

Several small pans at the same heat level

OR

1 large dish



2 Independent Cooking Zones:

Cooking at the front, at the back or on the 2 simultaneously, at different powers.

ECONOMICAL COOKING

Induction is quick and economical. It only takes 4 min 40' to bring 2 litres of water to a boil and induction only consumes 225W, as compared to 8min 20' and 390W for a gas burner*.

*2.8 kW induction cooking zone and a 3.5 kW gas burner.

PRECISION COOKING

With induction technology, the cooking hob generates heat exclusively on contact with cookware through a phenomenon of "induced" current produced in the bottom of the cookware, which instantaneously raises its temperature. This heat is then transferred to the food, which is simmered or seared depending on your settings.

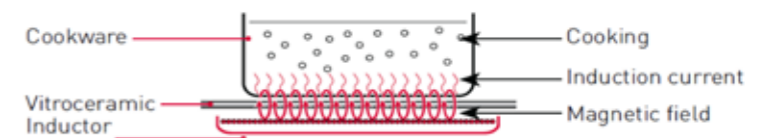

UNIFORM COOKING

COOKWARE TIPS

Induction doesn't warp the bottom of cookware. Eighty percent of cookware works with induction hobs, which are compatible with enamel, mixed stainless steel, cast iron and mixed aluminium.

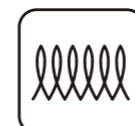

Check if your cookware is induction friendly by locating the induction-compatible symbol usually marked at the bottom of the cookware or on its packaging.

UNIFORMED COOKING

Brandt's exclusive technology optimises heat distribution throughout the cookware. Brandt has provided its inductors with an exclusive technology that makes cooking perfectly uniform over the entire surface of the cookware.



INDUCTION HOBS 3 ZONES

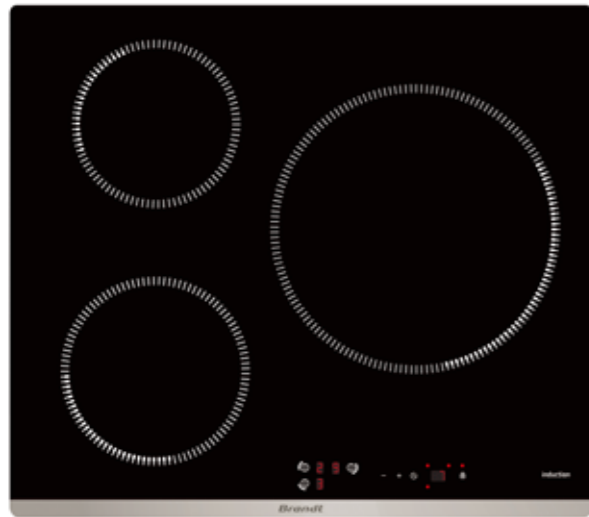

BPI6314B

- 60cm Width**
- 3 Zones**
- Electronic Touch Sensitive Controls**
- 9 Power Levels**
- Booster**
- 10 Safety Features**
- Vitroc ceramic Glass Top

18cm - 2800W /
16cm - 2000W /
28cm - 3600W
99 Minutes Timer
Child Lock
Product Dimensions (mm):
H64 x W580 x D510
Built In Dimensions (mm):
W560 x D490



BVCCert. 6011825

Installation Diagram BPI6314B

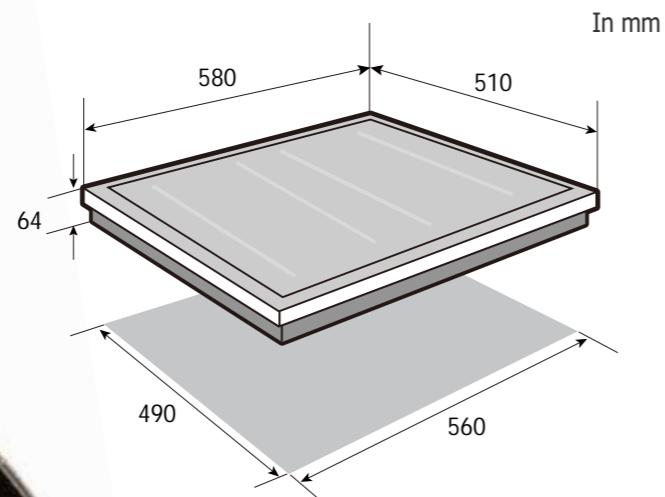

INDUCTION HOBS 2 ZONES AND DOMINO



BPI6230BL

- 75cm Width**
- 2 Zones**
- Electronic Touch Sensitive Controls**
- 9 Power Levels**
- Direct Access**
- 10 Safety Features**
- Vitroc ceramic Glass Top

Booster And Recall Function
21cm - 3100W /
18cm - 2800W Zones
99 Minutes Timer
Child Lock
Product Dimensions (mm):
H64 x W750 x D450
Built In Dimensions (mm):
W665 x D345



BVCCert. 6011825

BPI6210B

- 30cm Width**
- 2 Zones**
- Electronic Touch Sensitive Controls**
- 9 Power Levels**
- Booster**
- 10 Safety Features**
- Vitroc ceramic Glass Top

18cm - 2800W /
18cm - 2800W Zones
99 Minutes Timer
Child Lock
Product Dimensions (mm):
H64 x W288 x D510
Built In Dimensions (mm):
W265 x D490



BVCCert. 6011825

Installation Diagram BPI6230BL

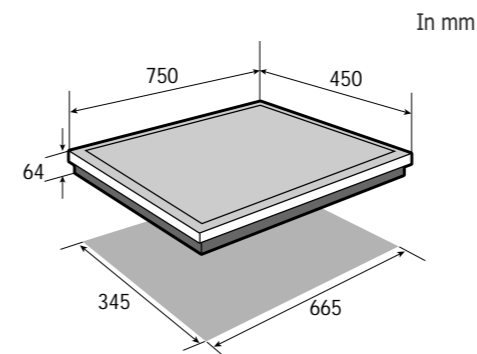

Installation Diagram BPI6210B

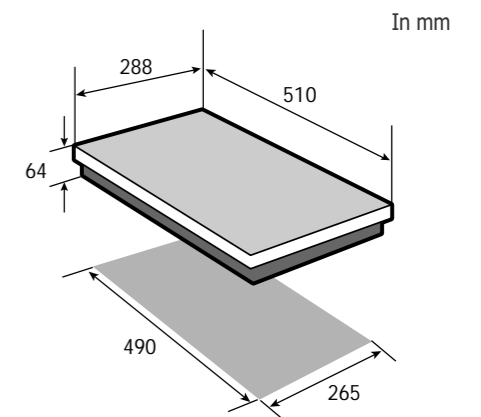

EASY MAINTENANCE

Induction leaves the surface around the cooking zone at a low temperature, which prevents spills from sticking to the hob. Just wipe it down with a sponge to make your hob shine.



FUNCTIONALITY AND PERFORMANCE

FOR EFFICIENT REMOVAL OF ODOURS AND FUMES

Choose from 3 to 4 speed settings to suit your cooking needs. Equipped with cassette filters and activated charcoal filters, Brandt hoods ensure optimum grease filtration and odour capture. A filter saturation light (available for selected models) also alerts you when it is necessary to clean or change them.



EASY USAGE

Brandt hoods make it easy to activate your needed programmes! You are guided by the electronic control system with speed display, backlit keys and soft keys for easy usage!



EUROPEAN ENERGY LABEL : A MARKER OF EXCELLENCE IN ENERGY CONSUMPTION AND PERFORMANCE

LOOK TO THE « ENERGY LABEL »

Brandt practices absolute transparency with every product carrying the relevant consumption labels for your easy reference.

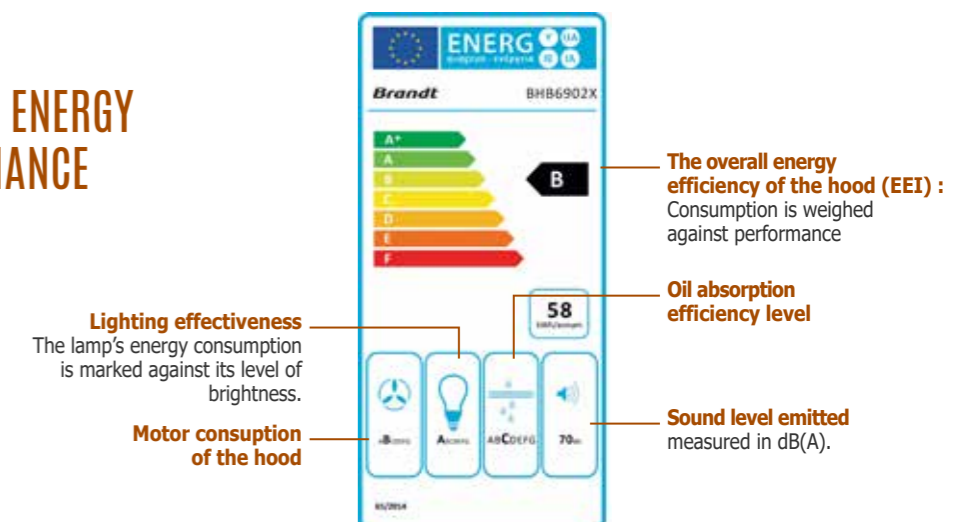

BRANDT HELP YOU DO THE SELECTION!

WHICH HOOD SUITS YOU MOST?

Chose the design and hood type that better blends in with your kitchen. The Brandt's hood range presents new models that are lined up with the current design tendencies and they perfectly integrate with the other electrical appliances for your kitchen.



DECORATIVE (WALL-MOUNT)

Designed for installation on the wall, Brandt decorative(wall-mount) hoods are sure to be a subtle statement piece in any kitchen.



ISLAND

Designed to be suspended from the ceiling over a central island unit, the sleek aesthetics create a stylish focal point for the kitchen.



SLIMLINE

For installation under a overhung kitchen to provide effective removal of odours and cooking fumes.



TELESCOPIC

Designed to be flush into a overhung kitchen cabinet, a Telescopic hood extends when required for the best possible performance.

SEVERAL ESSENTIAL CRITERIA

POINTS TO BE TAKEN INTO CONSIDERATION WHEN CHOOSING THE HOOD BEST SUITED TO YOUR NEEDS.

The kitchen size is not, the only factor to consider when choosing the right hood. The following rudimentary calculation will help you determine the adequate suction power for the best results.

MEASURE THE VOLUME OF YOUR KITCHEN

(e.g.) $4 \times 3 \times 3 = 36\text{m}^3$

As a kitchen's ambient air is renewed 10 to 12 times per hour, **multiply the volume by 10** to get adequate power (e.g. $36 \times 10 = 360\text{m}^3/\text{hr}$). As per example, a $400\text{m}^3/\text{hr}$ evacuation hood would be ideal or sufficient.

In recycling or if your kitchen is open (and subject to air disturbances), it might be wise to opt for a slightly more powerful hood.

THE SIZE OF THE HOB

For optimal suction, the width of the hood must be the same size or larger than the hob.

COOKING HABITS

To make the right choice, take into account your use of the hood (frequency of cooking, type of dishes (light, oily), number of dishes cooked simultaneously, etc)

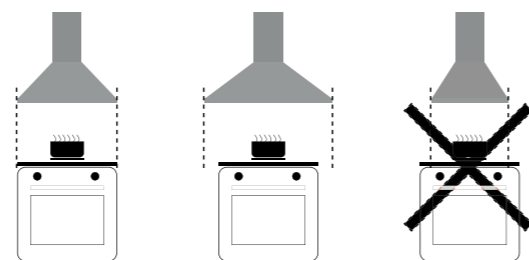

HOODS: THINGS YOU NEED TO KNOW

GET RID OF ODOURS AND COOKING FUMES WITH BRANDT HOODS

Brandt hoods offer you 2 types of installation that are best suited to your needs and the constraints of your kitchen.

EXTRACTION

TWO MODES ARE AVAILABLE TO CATER TO YOUR KITCHEN NEEDS

EVACUATION

Evacuation mode is ideal because the intake air (charged with odours, steam and smoke) is pushed out. Connect your hood to an outlet to vent the vapours that pass through the cassette grease filter.

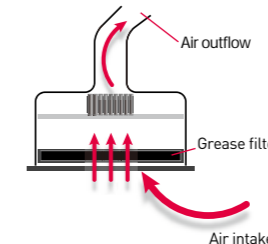

RECYCLING

If it's not possible to pipe out air, a recycling installation can clean out the air, ridding it of odours (via a charcoal filter) before diverting the clean air back into your home.

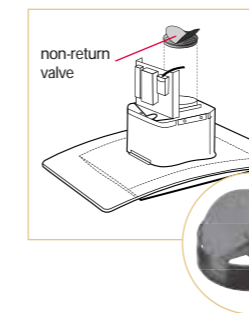
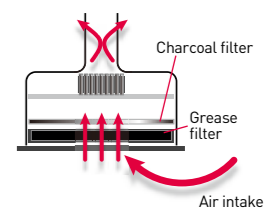

Brandt hoods are equipped with a non-return valve, an essential accessory so that the evacuated air is not bounced back inwards by winds.

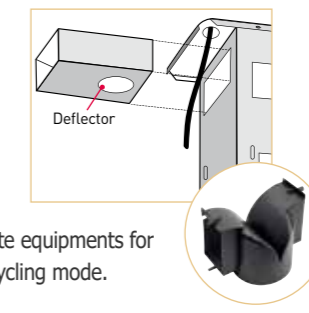

Brandt hoods are equipped with a deflector, to return route air through the gills.

Brandt hoods are supplied with complete equipments for perfect installation in evacuation or recycling mode.

FILTERS & MAINTENANCE

METAL GREASE FILTERS

All brandt hoods' grease filters are made of sturdy aluminum and contain a special mesh which captures and locks away the grease from cooking fumes. Once saturated, they can be easily removed and cleaned in a dishwasher or under warm soap water.

CARBON FILTERS

Carbon filters are used in recycling mode only and should be removed from any hood outside extraction. They work by drawing cooking fumes and odours into the carbon filter and neutralising the air through carbon particles before recycling clean air back into the kitchen. The carbon filters require replacement periodically, depending on frequency and type of cooking.



HOODS ISLAND



AD1188X

90cm Island Hood
Stainless Steel + Glass
Mechanical Controls
3 Speeds
740m³/h
 Sound Level: 63dBA
 2 Aluminium Filters
 (Dishwasher Safe)

LED Lighting
 Delivered In Recycling Mode
 Used For Extraction Or Recycling Mode
 Height Of Chimney (mm): 600 - 1100
 Product Dimensions Without Chimney (mm):
 H55 x W900 x D600

Installation Diagram AD1188X

In mm

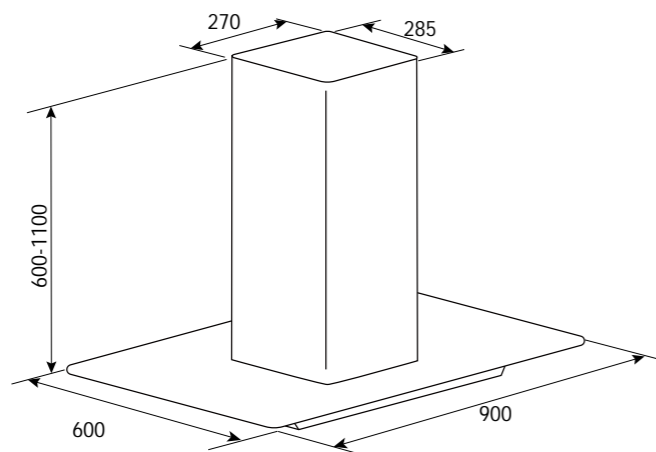

HOODS WALL MOUNT



AD658XC1

90cm Wall Mount Hood
Stainless Steel
Mechanical Controls
4 Speeds
1000m³/h
 Sound Level: 48dBA
 3 Aluminium Filters
 (Dishwasher Safe)

LED Lighting
 Delivered In Recycling Mode
 Used For Extraction Or Recycling Mode
 Height Of Chimney (mm): 514 - 1010
 Product Dimensions Without Chimney (mm):
 H110 x W900 x D500



Installation Diagram AD658XC1

In mm

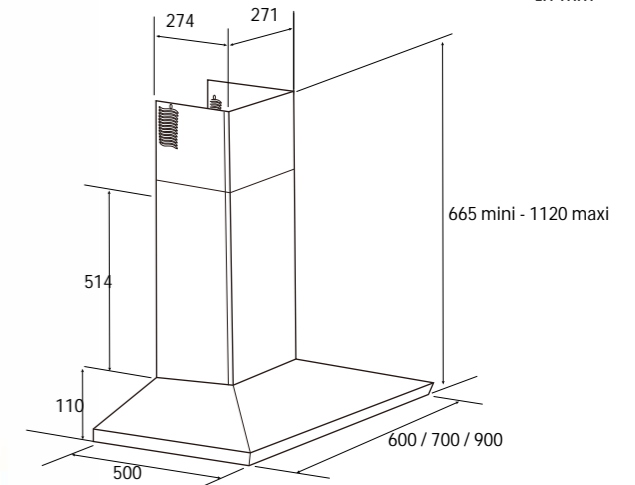

BRANDT HOODS WORK SILENTLY



THE PERFECT BALANCE BETWEEN CAPACITY AND SOUND LEVEL

As shown in the bar graphs, the Brandt Silent Inside extractor hood has obtained excellent results with regard to the draught capacity and the sound level generated.

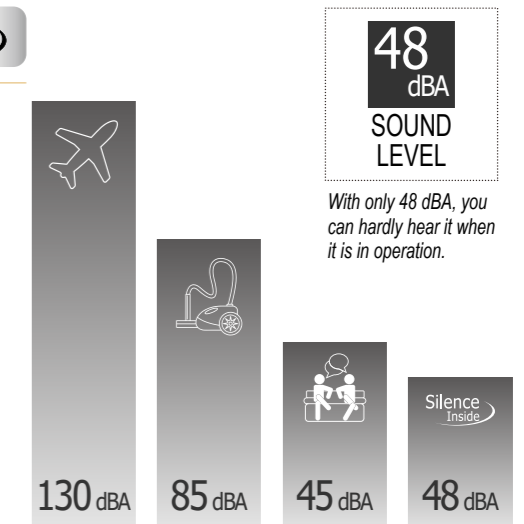



AD996XC

90cm Wall Mount Hood
Stainless Steel with Glass
Control Panel
Electronic Touch Controls
15 Minutes Delay Timer
950m³/h
 3 Speeds
 Sound Level: 65dBA

3 Stainless Steel Hook Filters
 (Dishwasher Safe)
 LED Lighting
 Delivered In Recycling Mode
 Used For Extraction Or Recycling Mode
 Height Of Chimney (mm): 470 - 940
 Product Dimensions Without Chimney
 (mm): H80 x W898 x D500

Installation Diagram AD996XC

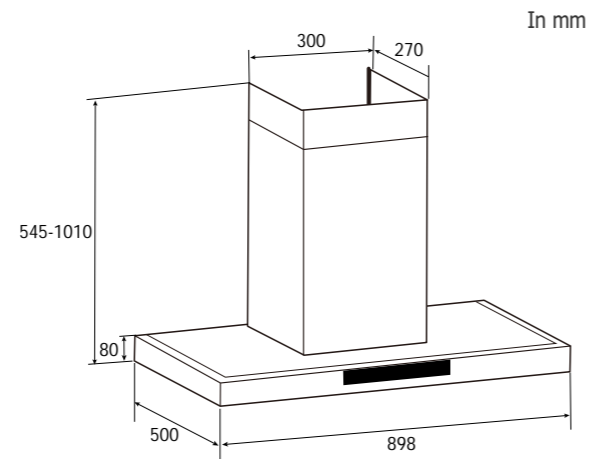

COOKING

n OVENS	29
n MICROWAVE OVENS	30
n STEAM OVENS	31
n INDUCTION HOBS	33
n HOODS	34

TECHNICAL SPECIFICATIONS

OVENS

REFERENCES				
Model	BOC7532LX	BOP7537LX/BOP7537BB	BOP7568LX	BOH7532LX
CHARACTERISTICS				
Type of Oven	Catalytic	Pyrolytic	Pyrolytic	Enamel
Oven Capacity	73L	73L	73L	73L
Type of Control	Electronic + Knob	Electronic + Knob	Electronic Touch	Electronic + Knob
Type of Display	LCD	LCD	Full Color TFT	LCD
Remaining Time Display	Yes	Yes	Yes	Yes
Type of Cleaning	Catalytic	Pyrolytic	Pyrolytic	Manual
Interior Lighting	Yes	Yes	Yes	Yes
WIFI	-	-	-	-
COOKING FUNCTIONS				
Functions	6	7	11	6
Circulating Heat	Yes	Yes	Yes	Yes
Grill with Fan	Yes	Yes	Yes	Yes
Variable Grill	Yes	Yes	Yes	Yes
Traditional Heat	Yes	Yes	Yes	Yes
Eco	Yes	Yes	Yes	Yes
Traditional Heat with Fan	-	-	Yes	-
Bottom Heat with Fan	-	Yes	Yes	-
Bottom Heat	-	-	-	-
Keep Warm	-	-	Yes	-
Steam Assisted	4(Fish), 4(Poultry)	4(Fish), 4(Poultry), 2(White Meat)	4(Fish), 4(Poultry), 2(White Meat)	4(Fish), 4(Poultry)
Cooking Guide	-	-	9 Dishes	-
Auto Cook	-	-	12 Dishes	-
Flavor Grill	-	-	-	-
Defrost	-	-	-	-
OPTIONS				
Smart Boost	-	Yes	Yes	-
Smart Assist	Yes	Yes	Yes	Yes
Demo Mode	-	Yes	Yes	Yes
Independent Timer	Yes	Yes	Yes	Yes
Delay End	Yes	Yes	Yes	Yes
Sound	Yes	Yes	Yes	Yes
ACCESSORIES				
45mm Drip Tray	1	1	1	1
20mm Pastry Tray	1	1	1	1
Safety Wire Rack	1	1	1	1
Adjustable Telescopic Railing	-	1	2	-
Catalytic Liners	Yes	-	-	-
STRUCTURE				
Material of Door Façade	Glass with Stainless Steel trimming	Glass with Stainless Steel trimming (BOP7537LX) Glass with Matt Black Trimming (BOP7537BB)	Glass with Stainless Steel panel	Glass with Stainless Steel trimming
SECURITIES				
Door Lock	-	Yes	Yes	-
Cool Door	-	Yes	Yes	-
Ventilated Door	Yes	-	-	Yes
Soft Close	-	-	Yes	-
Child Lock	Yes	Yes	Yes	Yes
Auto Stop	Yes	Yes	Yes	Yes
CONNECTIONS				
Total Power (W)	2650	3385	3385	2650
Amphere	13 / 15	15	15	13 / 15
Hertz	50 / 60	50 / 60	50 / 60	50 / 60
Plug	Without	Without	Without	Without
Cable Length (cm)	115	115	115	115
PRODUCT DIMENSIONS				
Actual (H x W x D) mm	596 x 592 x 544	596 x 592 x 544	596 x 592 x 544	596 x 592 x 544
Built In (H x W x D) mm	585 x 560 x ≥545	585 x 560 x ≥545	585 x 560 x ≥545	585 x 560 x ≥545
Net Weight (kg)	32.1	37.6	38.6	30.6
Gross Weight (kg)	33.5	39.2	39.9	32.7

TECHNICAL SPECIFICATIONS

MICROWAVE OVENS

REFERENCES		
Model	BMS7120X / BMS7120B	BKC7153LX
CHARACTERISTICS		
Type of Microwave	Solo	Combi
Microwave Capacity	26L	40L
Max. Microwave Power (W)	900	1000
Type of Control	Electronic Touch	Electronic Touch
Type of Display	LCD	LCD
Remaining Time Display	Yes	Yes
Interior Lighting	Yes	Yes
COOKING FUNCTIONS		
Functions	4	10
Microwave	Yes	Yes
Circulating Heat	-	Yes
Grill with Fan	-	Yes
Variable Grill	-	Yes
Microwave + Circulating Heat	-	Yes
Microwave + High Grill	-	Yes
Microwave + Low Grill	-	Yes
Defrosting	Yes	Yes
Cooking Guide	2 Dishes	15 Dishes
Defrosting Guide	4 Programs	3 Programs
OPTIONS		
Keep Warm	-	Yes
Smart Assist	Yes	Yes
MEMO	-	Yes
Delay End	-	Yes
Independent Timer	Yes	Yes
Sound	Yes	Yes
Turn Table stop	Yes	Yes
ACCESSORIES		
Turn Table	1	1
Glass Drip Tray	-	1
Wire Rack	-	-
STRUCTURE		
Material of Door Façade	Glass with Stainless Steel trimming (BMS7120X) Glass with Matt Black Trimming (BMS7120B)	Glass with Stainless Steel trimming
SECURITIES		
Child Lock	Yes	Yes
Auto Stop	Yes	Yes
CONNECTIONS		
Total Power (w)	1550	3400
Amphere	13	15
Hertz	50	50
Plug	European	-
Cable Length (cm)	138	130
PRODUCT DIMENSIONS		
Actual (H x W x D) mm	390 x 592 x 474	456 x 592 x 547
Built In (H x W x D) mm	380 x 560 x ≥550	450 x 560 x ≥550
Net Weight (kg)	20.68	38.95
Gross Weight (kg)	22.68	42.15

TECHNICAL SPECIFICATIONS

STEAM OVEN

REFERENCES	
Model	BKV7132LX
CHARACTERISTICS	
Type of Oven	Steam
Oven Capacity	29L
Type of Control	Electronic + Knob
Type of Display	LCD
Remaining Time Display	Yes
Type of Cleaning	Manual
Interior Lighting	Yes
COOKING FUNCTIONS	
Functions	11
Vegetables	Yes
Fish	Yes
Meat	Yes
Shellfish	Yes
Prepared Meals	Yes
Cereals	Yes
Yogurt	Yes
Reheating	Yes
Keep Warm	Yes
Defrosting	Yes
Manual	Yes
OPTIONS	
Smart Assist	Yes
Demo Mode	Yes
Independent Timer	Yes
Delay End	Yes
Sound	Yes
ACCESSORIES	
Perforated Drip Tray	1
Drip Tray	1
Safety Wire Rack	1
2nd Steam Tier (KITVAPIX)	Optional (Additional Purchase)
STRUCTURE	
Material of Door Façade	Glass with Stainless Steel trimming
SECURITIES	
Door Lock	-
Ventilated Door	Yes
Child Lock	Yes
Water Tank Indicator	Yes
Auto Stop	Yes
CONNECTIONS	
Total Power (W)	1770
Amphere	13
Hertz	50 / 60
Plug	Without
Cable Length (cm)	105
PRODUCT DIMENSIONS	
Actual (H x W x D) mm	456 x 592 x 547
Built In (H x W x D) mm	450 x 560 x ≥550
Net Weight (kg)	21.55
Gross Weight (kg)	24.45

INSTALLING YOUR INDUCTION HOB BUILT-IN

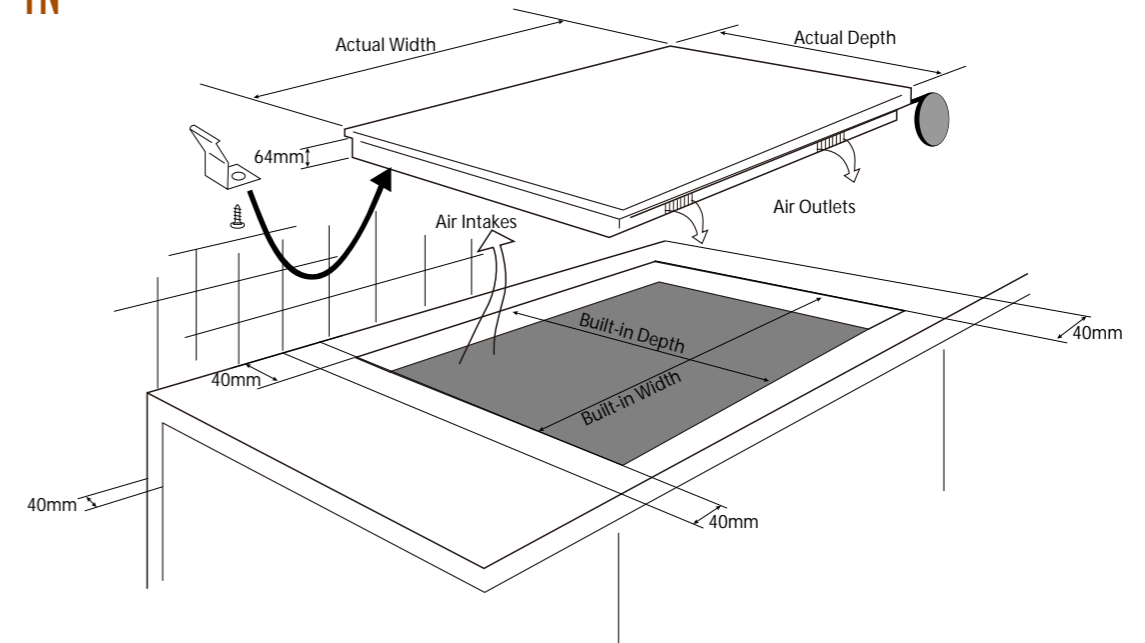

PROPER POSITIONING

Your hob should be positioned so that the plug-in unit is accessible, so you can easily switch it on and off. The distance between the edge of your appliance and the side and rear walls (or partitions) must be at least four centimeters.

Note: Please consider the size of your cookware before installation; ensure ample space allowance between hob and wall. our appliance can be easily integrated above a cabinet, and oven or a built-in-ready household appliance. You must simply ensure that the air intakes (under the hob) and air outlets (under the front of the hob) are clear and free from obstruction.

BUILDING IN

Follow the diagram above.

Glue the foam seal underneath your appliance by following the outline of the worktop upon which your appliance will rest. This will allow you to achieve a watertight seal with the worktop.

ELECTRICAL SUPPLY

Most induction hobs require up to 16-32 amps for fast and powerful heating. In the event that high amperage is not available, use the minimum of 15 amps, but note that there will be a "sharing" of power between the different zones. This is normal.

TIP

if your oven is located below your hob, the hob's thermal safety measures forbid the simultaneous use of the hob and the pyrolysis program of your oven. Your hob is equipped with an anti-overheating safety device.

This safety feature can be activated, for example, when the hob is installed over an oven that is not sufficiently insulate. If this occurs, a series of small lines appear in the control panel. In this case, we recommend that you increase the ventilation of your hob by creating an opening in the side of your cabinet (8 cm x 5 cm).

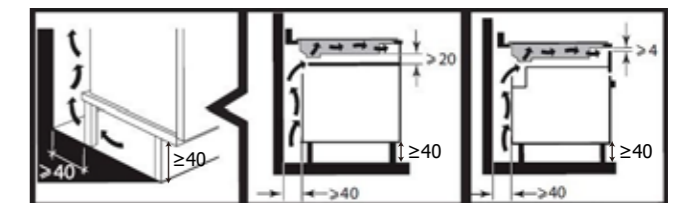

WARNING

You must ensure that the air intakes located under your hob remains clear at all times. For all type of installation, your induction hob needs proper ventilation. Do not install above a drawer or sealed unit. The hob must be able to draw air from its underneath.

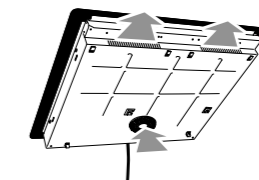

TECHNICAL SPECIFICATIONS

INDUCTION HOBS

REFERENCES				
Model	BPI6449BL	BPI6314B	BPI6230BL	BPI6210B
CHARACTERISTICS				
Width	80cm	60cm	75cm	30cm
Number of Zones	4	3	2	2
HoriZone	Yes	-	-	-
Glass Material				
Type of Control	Electronic Touch Sensitive	Electronic Touch Sensitive	Electronic Touch Sensitive	Electronic Touch Sensitive
Number of Power Levels	9	9	9	9
Boost Function	Yes	Yes	Yes	Yes
Direct Access Function	Yes	-	Yes	-
Timer	4 x 99mins	3 x 99mins	2 x 99mins	2 x 99mins
ZONES				
Left	40cm x 23cm - 4000W	-	21cm - 3100W	-
Right	18cm - 2800W	28cm - 3600W	18cm - 2800W	-
Front Right	-	-	-	-
Front Left	-	18cm - 2800W	-	-
Rear Right	-	-	-	-
Rear Left	-	16cm - 2000W	-	-
Center	21cm - 3100W	-	-	-
Front Center	-	-	-	18cm - 2800W
Rear Center	-	-	-	18cm - 2800W
SECURITIES				
Pack 10 Safety Features	Yes	Yes	Yes	Yes
CONNECTIONS				
Total Power (W)	7200	7200	3600	3600
Amphere	32	32	15	15
Hertz	50 / 60	50 / 60	50 / 60	50 / 60
Plug	-	-	-	-
Cable Length (cm)	130	130	130	130
PRODUCT DIMENSIONS				
Actual (H x W x D) mm	64 x 770 x 510	64 x 580 x 510	64 x 750 x 450	64 x 288 x 510
Built In (W x D) mm	750 x 490	560 x 490	665 x 345	265 x 490
Net Weight (kg)	13.5	10.1	9.5	5.5
Gross Weight (kg)	15	11	10.5	7.5
HONG KONG ENERGY LABEL				
Grade			4	4

TECHNICAL SPECIFICATIONS

HOODS

REFERENCES			
Model	AD658XC1	AD996XC	AD1188X
CHARACTERISTICS			
Type of Hood	Wall Mounted	Wall Mounted	Island
Width	90cm	90cm	90cm
Aesthetic	Stainless Steel	Stainless Steel with Glass Control Panel	Stainless Steel + Glass
Type of Control	Mechanical Buttons	Electronic Touch	Mechanical Buttons
Type of Filters	Aluminium	Stainless Steel	Aluminium
Number of Filters	3	3	2
Default Mode of Installation	Recycling	Recycling	Recycling
Extraction / Recycling mode	Yes / Yes	Yes / Yes	Yes / Yes
PERFORMANCE			
Number of Motors	1	1	2
Number of Speeds	4	3	3
Maximum Suction Power	1000m³/h	950m³/h	740m³/h
Delay Timer	-	15mins	-
ACCESSORIES			
Charcoal Filter	3	1	2
Flexible Duct	-	Yes	-
Adaptor	Yes	Yes	Yes
Air Deflector (For Recycling)	Yes	Yes	Yes
SECURITIES			
Auto Stop	Yes	Yes	Yes
CONNECTIONS			
Total Power (W)	374	407	96
Amphere	10	10	10
Hertz	50 / 60	50	50
Plug	-	-	European
Cable Length (cm)	90	100	90
PRODUCT DIMENSIONS			
Chimney Height (mm)	514 - 1010	470 - 940	600 - 1100
Actual without Chimney (HxWxD) mm	110 x 900 x 500	80 x 898 x 500	55 x 900 x 600
Built In (H x W x D) mm	-	-	-
Net Weight (kg)	14.5	18	31.5
Gross Weight (kg)	15.84	21	37.5